



FREE FLEX CONDENSING BOILERS - SUBMITTAL DATA SHEET

RATINGS AND CAPACITIES		
Input - Low Fire	200,000	BTU/HR
Input - High Fire	1,000,000	BTU/HR
Output - High Fire	950,000	BTU/HR
Boiler Horsepower	28.4	BHP
Thermal Efficiency	95.0%	
Low Fire Thermal Efficiency	Up to 99%	
Heating Surface	125	Sq.Ft.
Water Content	19.7	Gallons
Fuel		
Natural Gas		
Firing Rate	Full Modulation	
Burner Turndown	5:1	
Low NOx Emissions	Capable, Consult Factory	
Inlet Gas Pressure (NG)	4" wc	Min.
	14" wc	Max.
Shipping Weight, Approximate	1,620	lbs

ASME Section IV (Max 160 PSIG / 210°F)	
ETL Certified to UL 795 and CAN 3.1.1	

DIMENSIONS / CONNECTIONS	
- Height	63 - 3/16"
- Width	28"
- Length	71-5/16"
- Supply / Return Connections	3" Victaulic
- Vent / Air Intake Connections	6"
- Condensate / Boiler Drain Conn.	1"
- Gas Connection	1"

STANDARD EQUIPMENT	
- ASME Stainless Steel Heat Exchanger	
- Stainless Steel Mesh Pre-Mix Burner	
- Variable Speed Combustion Blower	
- Concert Boiler Control™ (24v)	
> 7" Color Touch Screen	
> Peer-To-Peer Boiler Communications (Up to 8 Units)	
> Energy Management System (EMS) Interface	
> USB Data Port Transfer	
> Self-Guiding Diagnostics	
> Unmatched Archives	
- High Limit Temperature Control, Manual Reset	
- Blower Motor, 1/2 HP	
- Water Flow Switch	
- Low Water Cutoff, Manual Reset	
- Condensate Trap	
- Blocked Condensate Switch	
- Pressure Relief Valve	
- Pressure / Temperature Gauge	
- Supply & Return Temperature Sensors	
- Flue Gas Temperature Sensor	
- Modulating Gas Valve	
- Direct Spark Ignition / UV Scanner	
- High/Low Gas Pressure Switches, Manual Reset	
- High/Low Pre-Mix Pressure Switches	
- 120/1/60 Line Voltage (6.6 Amps)	
- Category IV Individual Venting with Engineered Vent System	
- Category II Common Venting with Engineered Vent System	
- Ducted or Room Combustion Air Intake	

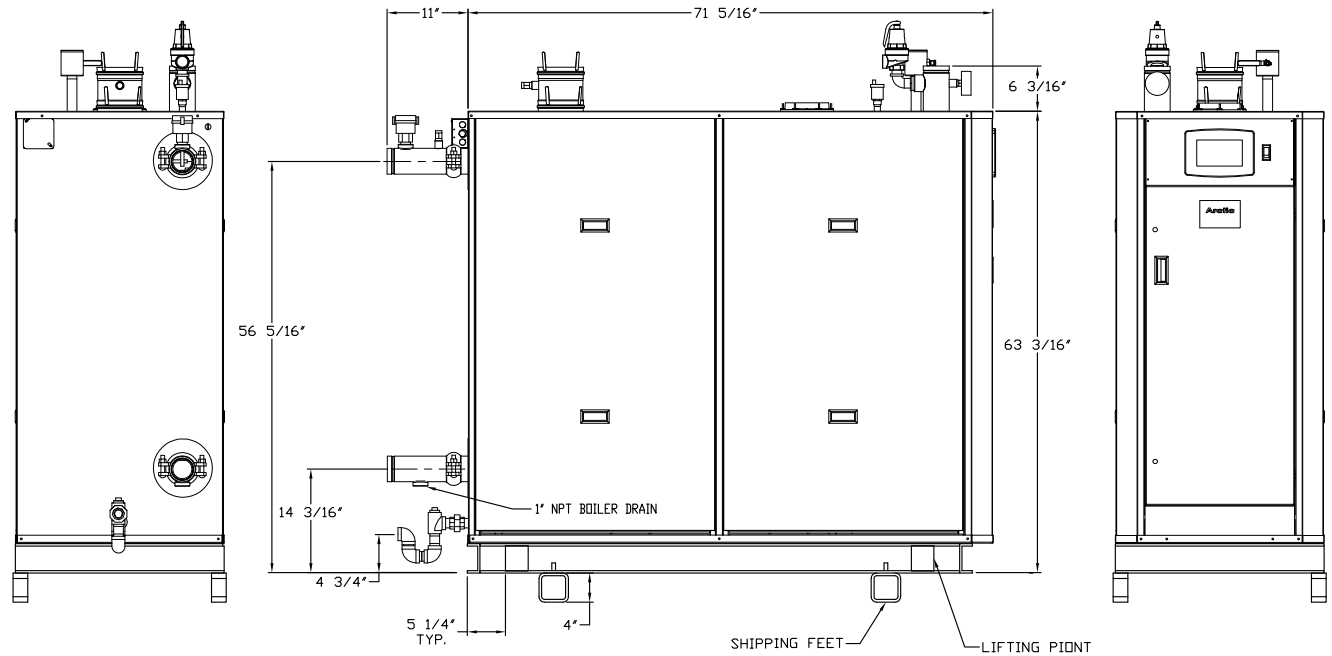
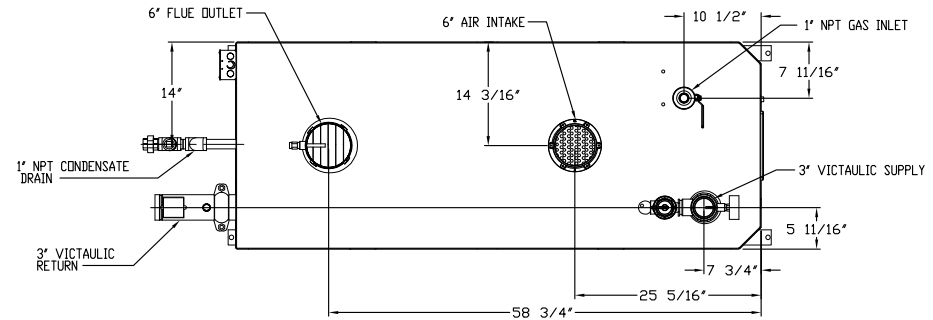

- NOTES:
1. Dimensions shown are for reference only
 2. See O&M for required installation clearances

FLOWS AND PRESSURE DROPS					
Delta T	Flow (GPM)	Δ P (Ft. Hd)	Delta T	Flow (GPM)	Δ P (Ft. Hd)
20°F Δ T (Max)	95	12.70	50°F Δ T	38	2.03
25°F Δ T	76	8.13	60°F Δ T	32	1.41
30°F Δ T	63	5.64	70°F Δ T	27	1.04
35°F Δ T	54	4.15	80°F Δ T	24	0.79
40°F Δ T	48	3.18	90°F Δ T	21	0.63
45°F Δ T	42	2.51	100°F Δ T (Min)	19	0.51

FF-1000

PROPERTY OF

BRYAN

783 N Chili Ave | Peru, IN 46970

Boiler Technology Leadership Since 1916

www.bryanboilers.com