



# BFIT CONDENSING BOILERS - SUBMITTAL DATA SHEET

RATINGS AND CAPACITIES		
Input - Low Fire .....	250,000	BTU/HR
Input - High Fire .....	1,250,000	BTU/HR
Output - High Fire .....	1,212,500	BTU/HR
Boiler Horsepower .....	36.2	BHP
Thermal Efficiency .....	97.0%	
Low Fire Thermal Efficiency .....	Up to 99%	
Heating Surface .....	91.6	Sq.Ft.
Water Content .....	11.0	Gallons
Fuel .....		
Natural Gas or Propane		
Firing Rate .....		
Full Modulation		
Burner Turndown .....		
5:1		
Low NOx Emissions .....		
< 10 ppm		
Inlet Gas Pressure (NG) .....		
4" wc Min.		
Inlet Gas Pressure (Propane) .....		
8" wc Min.		
14" wc Max.		
Shipping Weight, Approximate .....		
922 lbs		

ASME Section IV (Max 160 PSIG / 210°F)	
ETL Certified to UL 795 and CAN 3.1.1	

DIMENSIONS / CONNECTIONS	
- Height .....	42-3/4" (Note 1)
- Width .....	34-1/4" (Note 2)
- Length .....	45-1/2" (Note 3)
- Supply Connection .....	3" Grooved
- Return Connection .....	2-1/2" Grooved
- Vent / Air Intake Connections .....	8"
- Gas Connection .....	1" NPT

STANDARD EQUIPMENT	
- ASME Stainless Steel Heat Exchanger	
- Stainless Steel Pre-Mix Burner	
- Variable Speed Combustion Blower	
- Concert Control™ (24v)	
- High Limit Temperature Control, Manual Reset	
- Water Flow Switch	
- Low Water Cutoff, Manual Reset	
- Condensate Trap	
- Blocked Condensate Switch	
- ASME Pressure Relief Valve	
- Pressure / Temperature Gauge	
- Supply & Return Temperature Sensors	
- Flue Gas Temperature Sensor	
- Air Vent Valve	
- Modulating Gas Valve	
- Direct Spark Ignition and UV Scanner	
- High/Low Gas Pressure Switches, Manual Reset	
- Combustion Air Switch	
- Blocked Vent Switch	
- 120-208-240v/1/60 Line Voltage	
- Amp Draw: 120v (11.0); 208v (7.4) and 240v (6.5)	
- Category II and IV Venting	
- Individual or Common (Engineered) Vent System	
- CPVC, Polypropylene & Stainless Steel Acceptable *Material	
- Sealed or Room Combustion Air Intake	
- Up to 300 ft equivalent venting / air intake combined	

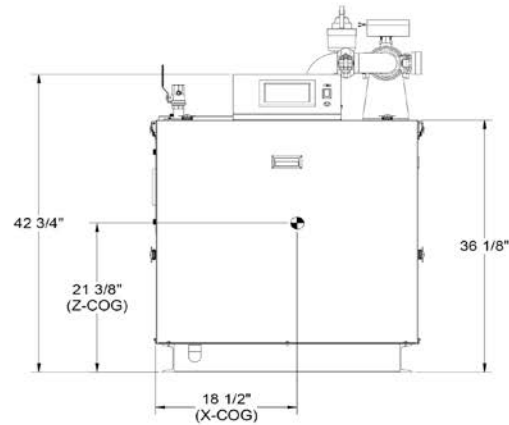

Front View

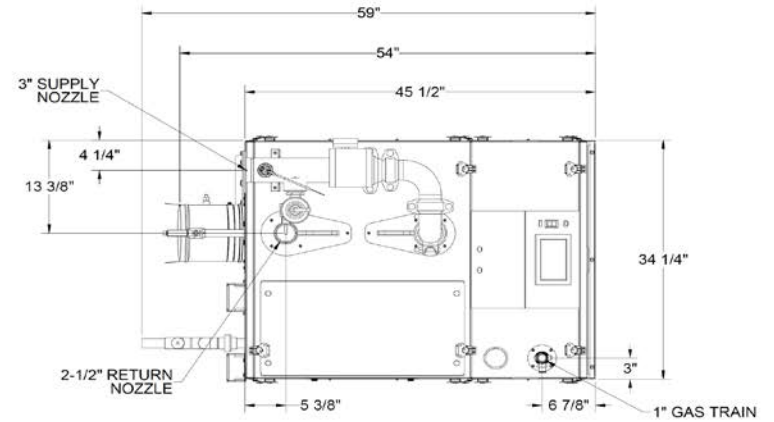

Top View

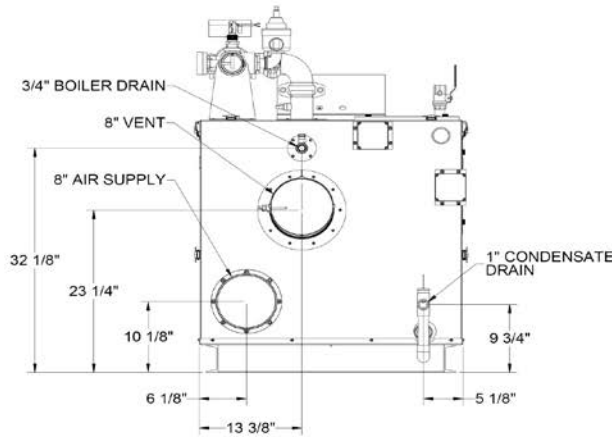

Rear View

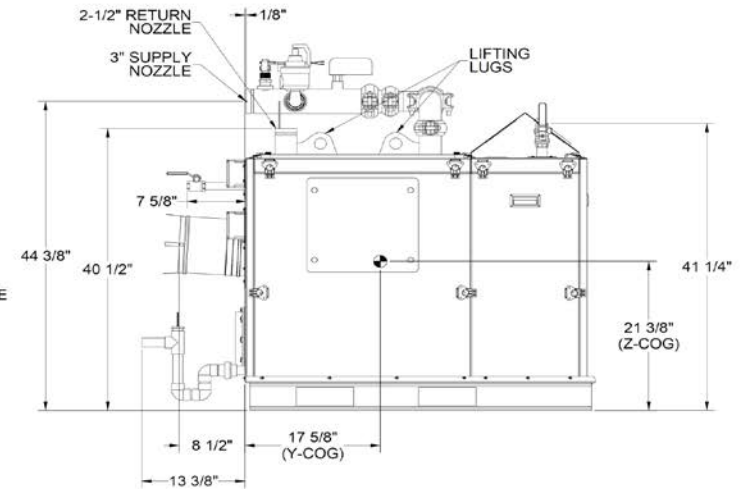

Left Side View

FLOWS AND PRESSURE DROPS		
Delta T	Flow (GPM)	Δ P (Ft. Hd)
20°F Δ T	121	16.0
25°F Δ T	97	11.0
30°F Δ T	81	7.2
35°F Δ T	69	6.1
40°F Δ T	61	5.2
45°F Δ T	54	3.8
50°F Δ T	50	3.0
55°F Δ T	44	2.8

**NOTES:**

1. Height dimension is from floor to top of control box.
2. Width does not include jacket butterfly clips that require 3/4" +/- clearance on each side.
3. Length is the measurement of the boiler skid base.
4. Dimensions shown are for reference only

\* 1. Flue system material shall be capable of continuous operation at 210°F or higher and shall be certified to UL 1738 – venting system for gas-burning appliances cat II, III and IV.

## BFIT-1250

PROPERTY OF

BRYAN®

783 N Chili Ave | Peru, IN 46970

---

Boiler Technology Leadership Since 1916  
www.bryanboilers.com