

**AB SERIES FORCED DRAFT 15# & 150#
STEAM BOILER (AB90-AB300)**

EFFECTIVE DATE: 8/12/10
REPLACES: 3/9/09

NOTES:

1. ALL DIMENSIONS ARE IN INCHES THOSE IN PARENTHESES ARE CENTIMETERS.
2. LOCATION DIMENSIONS ARE ALL $\pm 1/2"$.
3. GAS TRAIN, CONTROL AND BURNER CONFIGURATION WILL VARY DEPENDING ON JOB SPECIFICATIONS & CONDITIONS.
4. DIMENSIONS ARE SUBJECT TO CHANGE WITHOUT NOTICE. CONSULT FACTORY FOR CERTIFIED DIMENSIONS.
5. ALL FLANGES ARE 150# UNLESS OTHERWISE NOTED, FLANGES TO STRADDLE CENTER LINE.

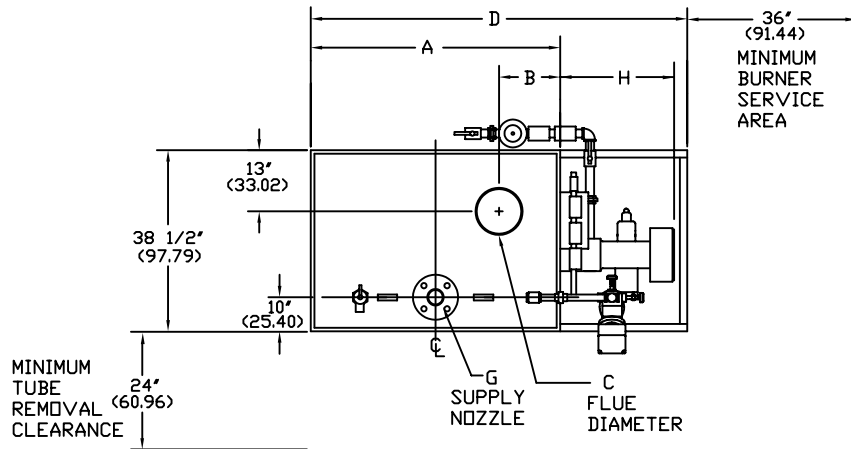

PLAN VIEW

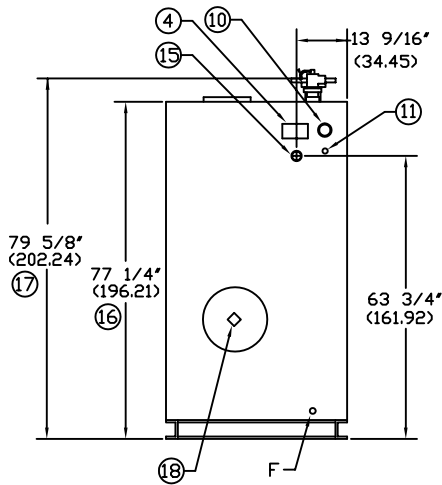

REAR VIEW

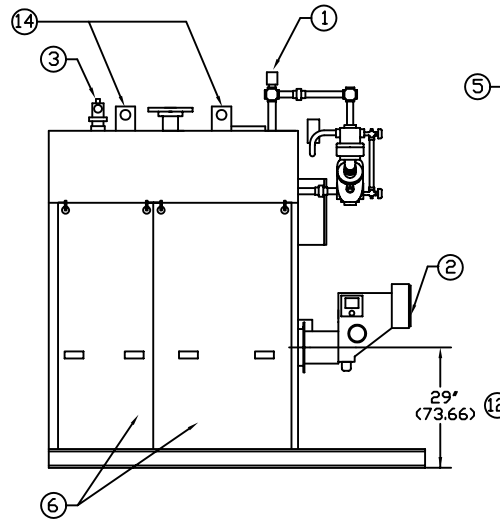

LEFT SIDE VIEW

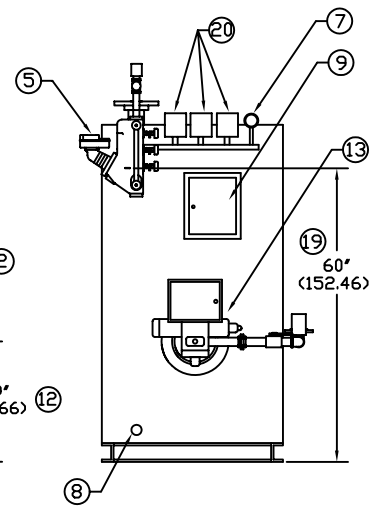

FRONT VIEW

1. PROBE TYPE AUX. L.W.C.D.	6. JACKET ACCESS PANELS	11. SURFACE BLOWDOWN - 1" NPT	16. HEIGHT OVER JACKET
2. FORCED DRAFT BURNER	7. PRESSURE GAUGE	12. BURNER CENTER LINE	17. HEIGHT OVER SUPPLY
3. RELIEF VALVE	8. CLNDUT./INSP. OPNG.-1 1/2"NPT	13. OIL PUMP LOCATION	18. FLAME OBSERVATION PORT
4. ASME NAMEPLATE	9. ELEC. ENCLOSURE -	14. LIFTING LUGS	19. MINIMUM SAFE WATER LEVEL
5. LWCD/PUMP CONTROL - 157	10. CLNDUT./INSP. OPNG. - 2" NPT	15. FEED CONNECTION 1 1/2" NPT	20. PRESSURE CONTROLS

BOILER MODEL	AB 90	AB 120	AB 150	AB 200	AB 250	AB 300
A-LENGTH OVER JACKET	44 15/16' (114.14)	54 3/16' (137.63)	63 1/2' (161.29)	78 15/16' (200.5)	94 7/16' (239.87)	108 13/16' (276.38)
B-FLUE LOCATION	12' (30.48)	12' (30.48)	12' (30.48)	16 1/2' (41.91)	15' (38.10)	15' (38.10)
C-FLUE DIAMETER	10' (25.40)	10' (25.40)	10' (25.40)	10' (25.40)	12' (30.48)	12' (30.48)
D-LENGTH OVER BASE	76' (193.04)	85 3/8' (216.83)	94 3/4' (240.66)	110' (279.40)	125 1/2' (318.77)	139 7/8' (355.28)
F-DRAIN/BLOWDOWN SIZE	15 PSI	1' (2.54)	1 1/4' (3.18)	1 1/4' (3.18)	1 1/2' (3.81)	1 1/2' (3.81)
	150 PSI	1' (2.54)	1' (2.54)	1' (2.54)	1' (2.54)	1' (2.54)
G-SUPPLY NOZZLE SIZE	15 PSI	4' (10.16)	4' (10.16)	6' (15.24)	6' (15.24)	6' (15.24)
	150 PSI	3' (7.62)	3' (7.62)	3' (7.62)	3' (7.62)	3' (7.62)

H- BURNER EXTENSION

CONSULT FACTORY FOR BURNER EXTENSIONS



BRYAN BOILERS

783 N CHILI AVE
PERU, INDIANA 46970

ORDER NO.:

ORDER REV. NO.:

FORM NO.: 1999

AB SERIES FORCED DRAFT STEAM BOILERS

BOILER MODEL		AB90	AB120	AB150	AB200	AB250	AB300
INPUT	MBH	900	1,200	1,500	2,000	2,500	3,000
	(KW)	263.7	351.6	439.5	586.0	732.5	879.0
OUTPUT*	MBH	720	960	1,200	1,600	2,000	2,400
	(KW)	211.0	281.3	351.6	468.8	586.0	703.2
BOILER HORSEPOWER	HP	21	29	36	48	60	72
	(KW)	206	281	351	468	586	703
TUBE DIAMETER	INCHES	1.00	1.00	1.00	1.00	1.00	1.00
	(CM)	2.54	2.54	2.54	2.54	2.54	2.54
NUMBER OF TUBES		26	35	44	59	74	88
PRESSURE VESSEL							
VOLUME	GAL	40	49	58	75	89	121
	(L)	151.4	185.5	219.5	283.9	336.9	458.0
HEATING SURFACE	SQ FT	113	148	184	244	303	360
	(SQ M)	10.5	13.8	17.1	22.7	28.2	33.5
STEAM OUTPUT*	LBS/HR	742	990	1,237	1,649	2,062	2,474
	(KG/HR)	336.7	448.9	561.2	748.2	935.3	1,122.3
OPERATING WEIGHT	LBS	2,934	3,459	3,984	4,776	5,542	6,109
	(KG)	1,330.7	1,568.8	1,807.0	2,166.2	2,514.0	2,771.1
SHIPPING WEIGHT	LBS	2,600	3,050	3,500	4,150	4,800	5,100
	(KG)	1,179.4	1,383.5	1,587.6	1,882.4	2,177.3	2,313.4

* Output based on nominal 80% of input. Actual combustion efficiencies will vary and are fuel dependant.