

EFF. DATE 6/01/04

REPL. NEW

# ILLUSTRATED PARTS LIST

FORM CLM-WATER-FD

PAGE: CLM - FD - W - 1

FOR CLM - SERIES, FORCED DRAFT, WATER BOILERS CLM90 THRU CLM300

## ORDERING INSTRUCTIONS

WHEN ORDERING PARTS FOR YOUR BRYAN BOILER OR HEATER,  
BE SURE TO INCLUDE THE FOLLOWING INFORMATION:

- |   |                          |
|---|--------------------------|
| 1. QUANTITY OF ITEMS REQUIRED                   | 4. BOILER MODEL NUMBER   |
| 2. PART NUMBER FROM THIS PARTS LIST (IF LISTED) | 5. BOILER SERIAL NUMBER  |
| 3. DESCRIPTION OF PART                          | 6. SHIPPING INSTRUCTIONS |

## EXAMPLE

PLEASE FORWARD TO US:

<u>QTY.</u>	<u>PART NO.</u>	<u>DESCRIPTION</u>	<u>FOR MODEL</u>	<u>BOILER SERIAL NO.</u>	<u>SHIP VIA</u>
5	400131	Boiler Tubes	CLM210	12345	Freight Truck

BRYAN BOILERS  
783 N. CHILI AVE. \* PERU \* INDIANA \* 46970  
PHONE: 765-473-6651 \* FAX: 765-473-3074  
E-MAIL: bryanboilers@iquest.net \* INTERNET: <http://www.bryanboilers.com>

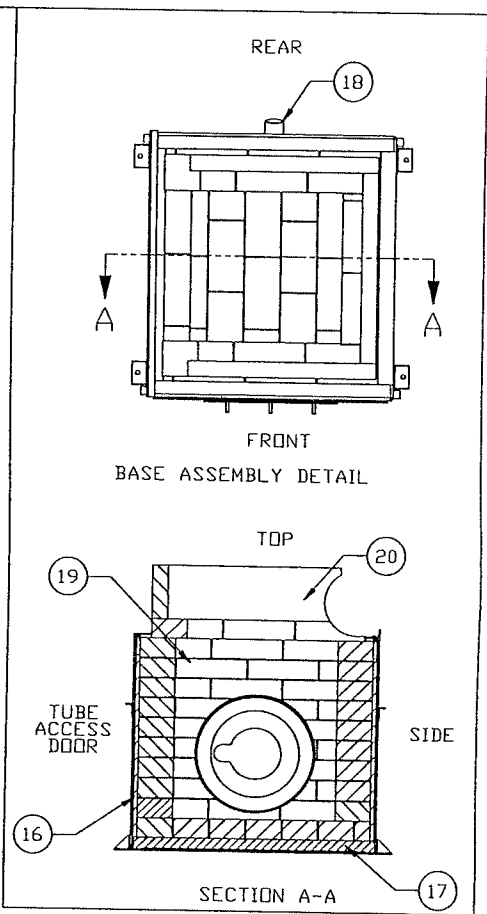
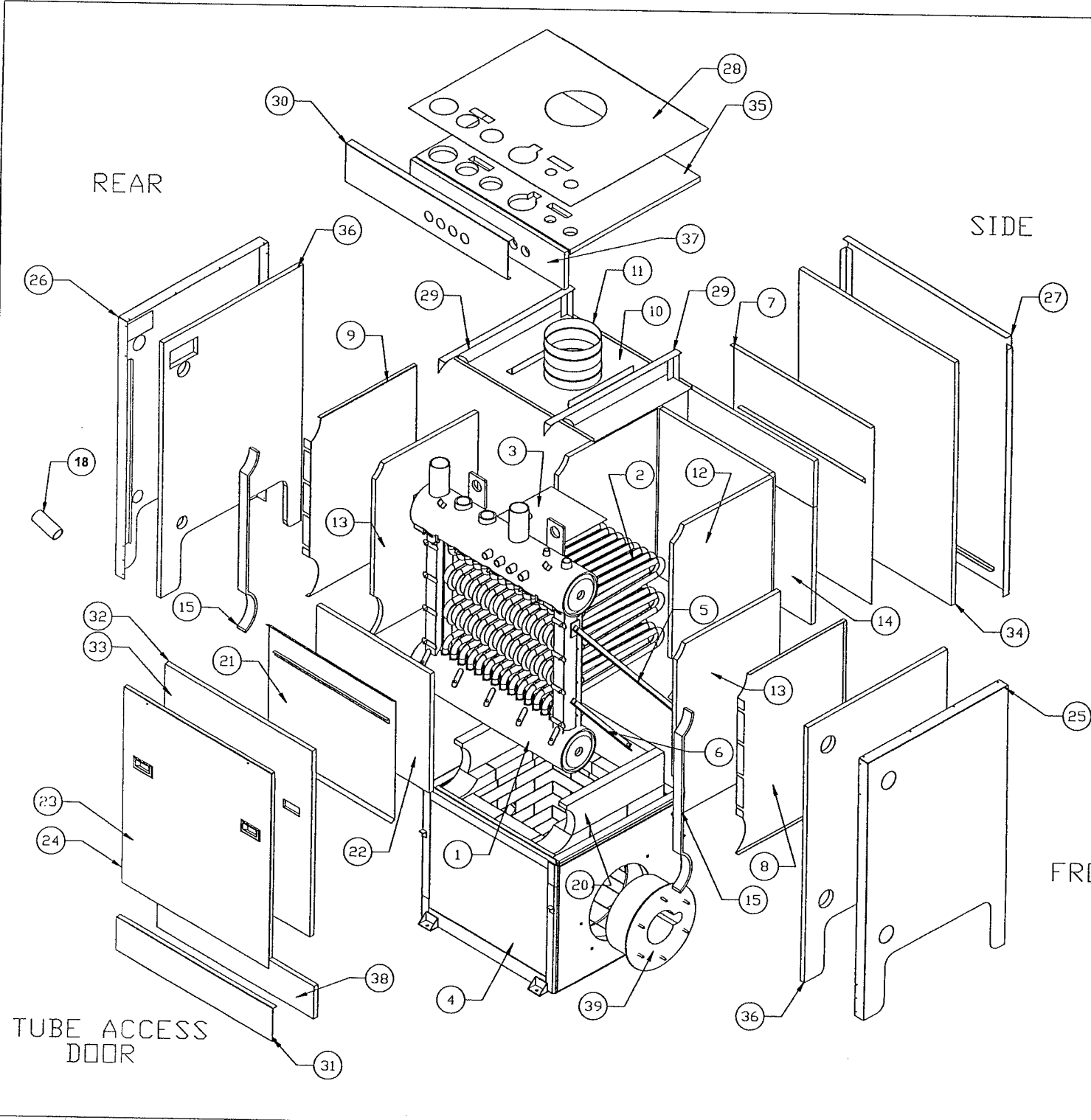

TUBE ACCESS DOOR

<b>B</b>		<b>BRYAN STEAM</b>	
783 North Chili Avenue		Peru, IN 46970	
PART TITLE			
CLM FORCED DRAFT WATER BOILER ASSEMBLY			
DESIGNED BY	DATE	SCALE	REV
JSL	11/14/03	NONE	FS
PART NO			A21166

EFF. DATE: 6/1/04

REPL: NEW

**CLM - SERIES  
FORCED DRAFT - WATER**

FORM: 2351

PAGE: CLM - FD - W - 2

ITEM	DESCRIPTION	CLM90-W		CLM120-W		CLM150-W		CLM180-W		CLM210-W		CLM240-W		CLM270-W		CLM300-W	
		REQ	PART	REQ	PART	REQ	PART	REQ	PART	REQ	PART	REQ	PART	REQ	PART	REQ	PART
			NO.		NO.		NO.		NO.		NO.		NO.		NO.		NO.
1	<b>PRESSURE VESSEL (with tubes)</b>	1	400111.90	1	400111.120	1	400111.150	1	400111.180	1	400111.210	1	400111.240	1	400111.270	1	400111.300
	<b>BOILER TUBE ASSEMBLY</b>																
2	Boiler Tube	27	400131	36	400131	45	400131	54	400131	63	400131	72	400131	81	400131	90	400131
	Boiler Tube Clamp Stud	26	25184	36	25184	44	25184	54	25184	62	25184	72	25184	80	25184	90	25184
	Tube Clamp	26	23622	36	23622	44	23622	54	23622	62	23622	72	23622	80	23622	90	23622
	Tube Clamp Nut	26	25114	36	25114	44	25114	54	25114	62	25114	72	25114	80	25114	90	25114
3	Tube Baffle																
	<b>BOILER BASE ASSEMBLY</b>																
4	<b>BOILER BASE ASSEMBLY</b>	1	4246	1	4247	1	4248	1	4249	1	4250	1	4251	1	4252	1	4253
5	Support Bar - (long) 42-1/8" (ft)	4	11002	4	11002	4	11002	4	11002	4	11002	4	11002	4	11002	4	11002
6	Support Bar - (short) - Knockdown Only 22-1/8" (ft)	2	11002	2	11002	2	11002	2	11002	2	11002	2	11002	2	11002	2	11002
	<b>FLUE COLLECTOR PANELS</b>																
7	Flue Collector - Side (Opposite Tube Panel)	1	300325.90	1	300325.120	1	300325.150	1	300325.180	1	300325.210	1	300325.240	1	300325.270	1	300325.300
8	Flue Collector - Front	1	300282	1	300282	1	300282	1	300282	1	300282	1	300282	1	300282	1	300282
9	Flue Collector - Rear	1	300282	1	300282	1	300282	1	300282	1	300282	1	300282	1	300282	1	300282
10	Flue Collector - Top	1	300288.90	1	300288.120	1	300288.150	1	300288.180	1	300288.210	1	300288.240	1	300288.270	1	300288.300
11	Flue Collector Stack Extension	1	28679	1	28679	1	28680	1	28681	1	28681	1	32183	1	32183	1	32183
	<b>FLUE COLLECTOR INSULATION</b>																
12	Flue Collector Tube Wrap (inswool)	1	300357.90	1	300357.120	1	300357.150	1	300357.180	1	300357.210	1	300357.240	1	300357.270	1	300357.300
13	Flue Collector Front/Rear Insulation 1" (thermofiber)	2	300358.90	2	300358.120	2	300358.150	2	300358.180	2	300358.210	2	300358.240	2	300358.270	2	300358.300
14	Flue Collector Side Insulation 1" (thermofiber)	1	300359.90	1	300359.120	1	300359.150	1	300359.180	1	300359.210	1	300359.240	1	300359.270	1	300359.300
15	Flue Collector Insulation Strips 6' x 3" x 1" (inswool)	2	24529	2	24529	2	24529	2	24529	2	24529	2	24529	2	24529	2	24529
	<b>COMBUSTION CHAMBER ASSEMBLY</b>																
16	Side Insulation Block 1/2" x 18" x 24" (sq. ft.)	14	24500	17	24500	21	24500	21	24500	28	24500	32	24500	33	24500	35	24500
17	Floor Insulation Block 1-1/2" x 24" x 36" (sq. ft.)	18	24504	21	24504	24	24504	25	24504	26	24504	30	24504	31	24504	33	24504
18	Fire Inspection Tube	1	8430	1	8430	1	8430	1	8430	1	8430	1	8430	1	8430	1	8430
	Nipple, 2" x 7"	1	22479	1	22479	1	22479	1	22479	1	22479	1	22479	1	22479	1	22479
	Pipe Cap 2"	1	22245	1	22245	1	22245	1	22245	1	22245	1	22245	1	22245	1	22245
	View Glass 1/4" x 2" Dia. Pyrex	1	28931	1	28931	1	28931	1	28931	1	28931	1	28931	1	28931	1	28931
	Rope Gasket 3/8" (ft.)	1	24621	1	24621	1	24621	1	24621	1	24621	1	24621	1	24621	1	24621
19	Combustion Chamber Brick - 2300° Fire	138	24541	164	24541	190	24541	217	24541	244	24541	271	24541	292	24541	319	24541
20	Refractory Tile 2"	4	24531	4	24531	5	24531	5	24531	5	24531	6	24531	6	24531	7	24531
	Refractory Cement (in pounds)	100	24550	150	24550	200	24550	250	24450	300	24450	325	24450	350	24450	375	24450



EFF. DATE: 6/01/04  
 REPL: NEW

**CLM - SERIES  
 FORCED DRAFT - WATER**

FORM: 2351  
 PAGE: CLM - FD - W - 4

ITEM	DESCRIPTION	CLM90-W		CLM120-W		CLM150-W		CLM180-W		CLM210-W		CLM240-W		CLM270-W		CLM300-W	
		REQ	PART NO.	REQ	PART NO.	REQ	PART NO.	REQ	PART NO.	REQ	PART NO.	REQ	PART NO.	REQ	PART NO.	REQ	PART NO.
<b>CONTROL EQUIPMENT LIST</b>																	
	Junction Box w/Cover or Control Box	<b>CONSULT EQUIPMENT LIST</b>															
	Terminal Strip *																
	Aquastat - Operator																
	Aquastat - High Limit																
	Aquastat Well																
	Low Water Cut Off																
	Wire Molding	1	25606	1	25606	1	25606	1	25606	1	25606	1	25606	1	25606	1	25606
<b>WATER TRIM</b>																	
	Comb.Temp/Press.Gauge	<b>CONSULT EQUIPMENT LIST</b>															
	Pressure Relief Valve																
<b>INDIRECT WATER HEATER</b>																	
	Indirect Heat Exchanger	<b>CONSULT EQUIPMENT LIST</b>															
	Heat Exchanger Gasket 8"	1	29189	1	29189	1	29189	1	20189	1	29189	1	29189	1	29189	1	29189
	Expansion Tank	<b>CONSULT EQUIPMENT LIST</b>															
	Boiler Fill Valve																
	Heat Exchanger Relief Valve (WT ONLY)																
	Pool Water Temperature Control (WP ONLY)																
<b>SERVICE TOOLS</b>																	
	Tube Puller **	1	28905	1	28905	1	28905	1	28905	1	28905	1	28905	1	28905	1	28905
	Tube Driver **	1	28901	1	28901	1	28901	1	28901	1	28901	1	28901	1	28901	1	28901
	Tube Brush **	1	28916	1	28916	1	28916	1	28916	1	28916	1	28916	1	28916	1	28916

\* Depends on Number of Terminals Required

\*\* Not Standard. Available Upon Request.