

FREE FLEX

Ultra-High Efficiency Commercial Condensing Boilers



Free to Move

- 95% AHRI Certified Efficiency
- 1000 - 3000 MBH
- Fully Field Repairable
- Lifetime Thermal Shock Warranty
- Variable-Primary or Primary/Secondary



B™ **BRYAN**® **BOILERS**

Designed and Manufactured in the U.S.A.



Bryan Built: Core Values Pacify Marketpla

How long will your condensing boiler last? If using a Free Flex from Bryan, the answer is LONGEVITY, consistent RELIABILITY, and unique SERVICEABILITY are welcomed into your facility. Bryan's Free Flex is built to last, with no unrepairable or stationary tube sheets at odds with burner temperature swings. Our design is a shock where no other competitive welded product dare go beyond 10 years. Our design includes 1st field replacement of tubes, an optional knockdown configuration to go where no

Uncommon & Serviceability Access

Maintenance accessibility is as critical part of the overall boiler design, and the Free Flex does not disappoint. Front, left-hand side, the jacket and flue collector doors are easily removed for full access to service and clean the heat exchanger and burner/blower/gas train assembly. Liberal heating surface throughout the pressure vessel evenly distributes heat transfer promoting longer product lifecycle. Tubes can be removed or replaced with simple hand tools in minutes. Commercial-grade controls used in the construction of the boiler can be purchased locally for fast repair.

Variable Primary or Primary/Secondary Piping

Not only are our tubes flexible, but so are the different ways to pipe Free-Flex. With low water pressure drops, the Free-Flex is able to operate in low flow designs, Variable-Primary, and traditional primary/secondary designs.

Knockdown Capability

Knockdown and condensing were never mentioned before in the same sentence...until now! The Free Flex is available in various knockdown configurations best suited to gain access into a building that other packaged boilers will not. Individual components will easily fit through a standard door opening and can be reassembled without requiring the services of an ASME welder. Depending on the needs, the Free Flex can be partially assembled or completely disassembled.

Reverse Construction

Reverse (mirror) construction is available when two boilers are needed for side-by-side installation. This allows full access to the heat exchanger, burner/blower/gas train assembly on the right-hand side instead of the standard left-hand side, keeping the footprint as small as possible in tight mechanical rooms.

Competitive Footprint

The Free Flex offers a competitive **installed** footprint. Connections are located at the top of the unit freeing the sides of cluttered piping that often get in the way of servicing the boiler. The jacket encompasses the flue outlet assembly that permits minimum clearances to the rear where other models must accommodate for venting in floor print.

Venting Category II and IV

Common venting with engineered vent systems.

HEAT EXCHANGER

At the heart of every Bryan Boiler design is the heat exchanger. Objects expand and contract when exposed to heat. This is no exception. With combustion temperatures reaching up to 2000°F, cooling during off cycles, only Bryan's design. Competitive models unwisely re-stressing material and sealants. Bryan's design also provide natural internal circulation of hot water, and lower velocity to optimize heat transfer.

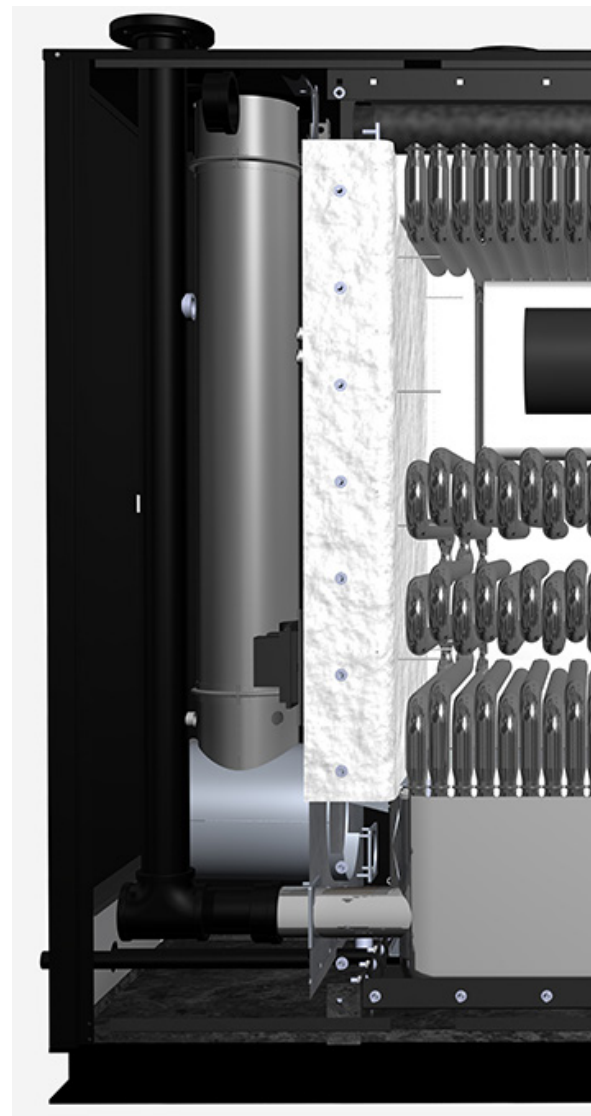
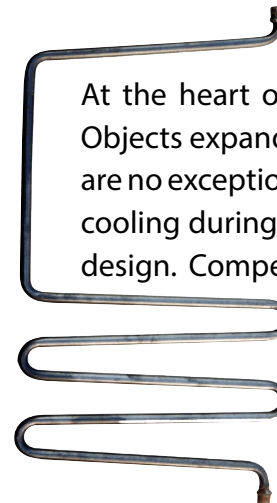

Free VOID of Longevity and Character

Free is a LIFETIME. With over a century designing and manufacturing boilers, our cornerstones of profound expertise in a deprived condensing landscape. This space is littered with “me too” replicas exhibiting endless welds and heat exchanger sets us apart. Only Bryan’s time-tested seal provides a lifetime guarantee against thermal stress. Our design also grants unequalled access for service and cleaning of the heat exchanger. This allows for an industry first: a condensing boiler that can fit and space-saving reverse construction for side-by-side installation.

Free – FREE TO MOVE!

Free beats our exclusive flexible watertube. Free is designed to temperature differentials and boilers operating at temperatures approaching 2000°F and drastically reduces thermal expansion by eliminating welds to hold back this movement. Free’s inclined flex tubes promote natural circulation, mixing of fluids and velocity through the tubes to prevent fouling and separation of solids.

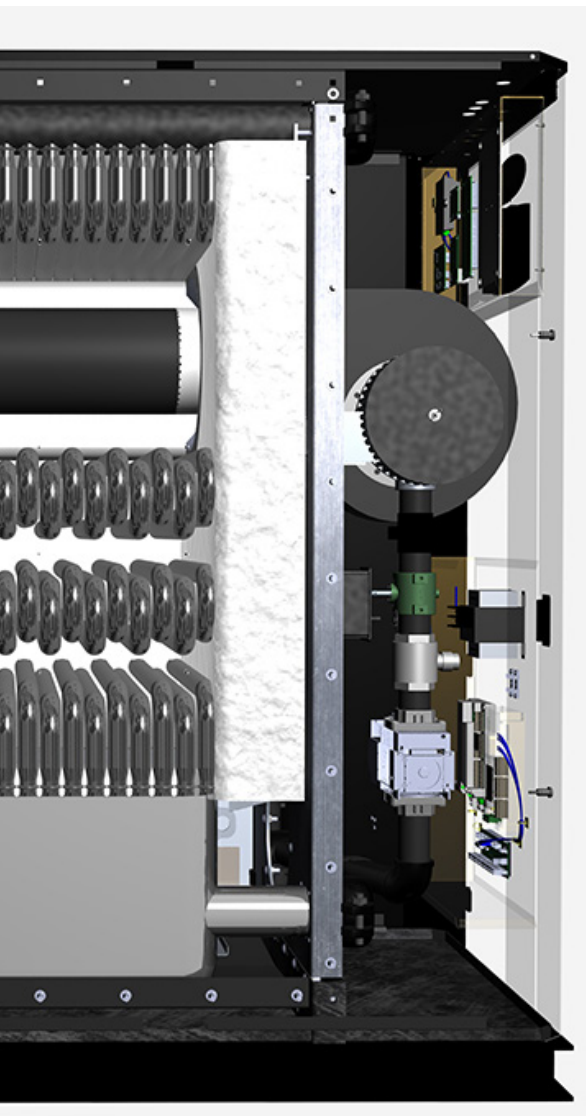
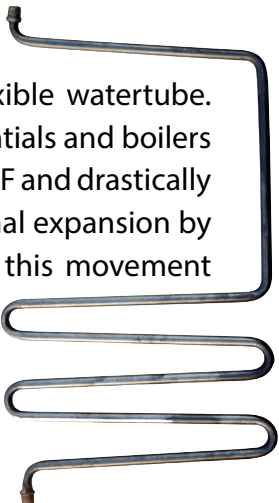

Lifetime Thermal Shock Guarantee

A swedged mechanical fit, free of welds, seals the tube to header allowing for simple and quick tube replacement should repairs ever be required. Not only is Free Flex the only repairable condensing boiler on the market, it is also backed by Bryan’s Thermal Shock Lifetime Seal Guarantee. Only Bryan can provide this assurance because we know our seal has worked for a century.



State-Of-The-Art Control System

Whether it be stand-alone, sequencing multiple boilers and/or communicating with a building management system, the Concert™ Boiler Control “checks all the boxes” for today’s needed control features and functions:

- Large 7” color touch screen display
- 5:1 Turndown (high turndown option)
- Two (2) temperature demand inputs
- Three (3) pump control
- Up to 8 unit boiler sequencing
- BMS interface
 - 4-20mA standard / 0-10v optional
 - Modbus standard
 - BacNET, Lonworks & other optional protocols
- USB data sharing port
- Energy efficiency enrichment technology
- Built-in diagnostics
- Huge archive database
- Time/date stamp on alarms and lockouts
- Domestic water priority
- Factory default settings
- Three level password security
- Frost protection
- Boiler sensor monitoring and control
- Low water flow safety control and indication
- Proportion integral derivative (PID) parameters
- Brown-out protection

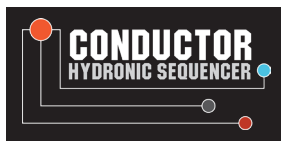

Harmonizing Boilers with Systems

Optional control panel integrates all makes of boilers (water or steam) for seamless, single-point connection with EMS. Improves efficiency and operation of condensing, non-condensing, hybrid or steam systems up to 8 units. “Smart Ops” select boiler type (condensing or non-condensing) based on load requirements and inputs of boilers of any size. Selectable Unison and/or Sequential modulation with base load ensures peak efficiency and maximum run time for all types of boiler technologies.



Bryan Free Flex

Ultra High Efficiency Commercial Condensing Boilers

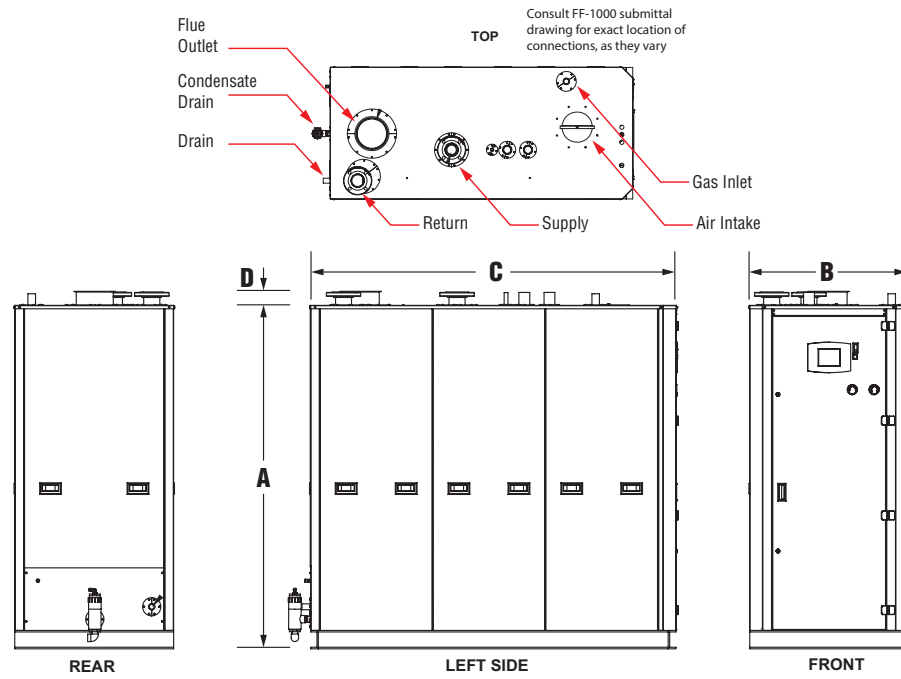

Specifications, Dimensions, & Ratings

MODEL	Ratings			THERM EFF. %	"A" EIGHT (IN.)	"B" WIDTH (IN.)	"C" LENGTH (IN.)	"D" CONN. HEIGHT (IN.)	SUPPLY/ RETURN CONN. (IN.)	VENT DIA. (IN.)	AIR INTAKE DIA. (IN.)	CONDENSATE & BOILER DRAIN CONN. (IN.)	GAS CONN. (IN.)	APPROX. SHIPPING WEIGHT (LBS)
	MIN INPUT (MBH)	MAX INPUT (MBH)	GROSS OUTPUT (MBH)											
FF-1000	200	1000	950	95.0	64	29	72	6	3 Victaulic	6	6	1	1	1620
FF-1500	300	1500	1425	95.0	75	35	80	3	3 Flange	8	8	1	2	2560
FF-2000	400	2000	1900	95.0	75	35	80	3	3 Flange	8	8	1	2	2560
FF-2500	500	2500	2375	95.0	75	35	93	3	3 Flange	10	10	1	2	3060
FF-3000	600	3000	2850	95.0	75	35	93	3	3 Flange	10	10	1	2	3060

PRESSURE VESSEL DESIGN

ASME certified stainless steel heat exchanger
 ASME Section IV-certified, "H" Stamp
 MAWP 160 PSIG & max temp 210°F
 Ten Year limited heat exchanger warranty
 Lifetime thermal shock warranty

COMBUSTION DESIGN

Stainless steel mesh pre-mix burner
 Low NOx emissions
 Full modulation, 5:1 turndown
 Natural gas (consult factory on LP gas)
 4" wc to 14" wc inlet gas pressure
 Direct spark ignition system/UV scanner
 High & Low Gas Pressure Switches, Manual Reset
 Variable speed combustion blower
 Air proving switch

BOILER EQUIPMENT

Concert Boiler Control™(24 Vac)
 High limit w/ manual reset safety temperature control
 Low water cutoff, manual reset
 Water flow switch
 Supply & return water temperature sensors
 Flue gas temperature sensor
 Air vent valve
 Condensate trap
 Blocked condensate switch
 Blocked vent air switch
 Pressure & temperature gauge
 ASME safety relief valve 50 psig
 (optional 30,60,75,100,125, or 150 psig)

VENTING

Air Intake - Ducted or Room Air
 Category IV Individual Venting with Engineered Vent System
 Category II Common Venting with Engineered Vent System

ELECTRICAL DESIGN

120 VAC / 60 Hertz / 1 phase power supply
 208-240 VAC / 60 Hertz / 1 phase power supply (FF-1500 to 3000)
 208-240-460 VAC / 60 Hertz / 1 phase or 3 phase power supply
 (FF-2000 to 3000)
 24 VAC low voltage control power supply

OPTIONS

Condensate neutralizer
 Header sensor, direct immersion
 Header sensor, well immersion (with well)
 Outdoor air reset sensor
 Knockdown configuration
 Reverse construction
 Communication gateway
 BMS signal converter kit
 Motorized zone valve



© 2020 Bryan Steam LLC – Leaders Since 1916
 783 N. Chili Ave., Peru, Indiana 46970 U.S.A.
 PH:765-473-6651, Fax: 765-473-3074
www.bryanboilers.com
 Email: inquiry@bryansteam.com