



# BFITW CONDENSING WATER HEATERS - SUBMITTAL DATA SHEET

RATINGS AND CAPACITIES		
Input - Low Fire .....	50,000	BTU/HR
Input - High Fire .....	500,000	BTU/HR
Output - High Fire .....	490,000	BTU/HR
DHW Recovery (40°F to 140° Rise)....	588	GPH
Thermal Efficiency .....	98.0%	
Heating Surface .....	39.1	Sq.Ft.
Water Content .....	4.3	Gallons
Fuel .....	Natural Gas or LP Gas	
Firing Rate .....	Full Modulation	
Burner Turndown .....	10:1	
Low NOx Emissions .....	< 10 ppm	
Inlet Gas Pressure (NG) .....	4" wc	Min.
Inlet Gas Pressure (LP) .....	8" wc	Min.
	14" wc	Max.
Shipping Weight, Approximate .....	470	lbs

ASME Section IV (Max 160 PSIG / 210°F)	
ETL Certified to ANSI Z21.10.3 / CSA4.3	
NSF/ANSI Standard 372	

DIMENSIONS / CONNECTIONS		
- Height .....	38-1/2"	(Note 1)
- Width .....	26-3/8"	(Note 2)
- Length .....	37-3/4"	(Note 3)
- Supply Connection .....	2" NPT	
- Return Connection .....	2" NPT	
- Vent / Air Intake Connections .....	4"	
- Gas Connection .....	3/4" NPT	

STANDARD EQUIPMENT	
- ASME Stainless Steel Heat Exchanger	
- Stainless Steel Pre-Mix Burner	
- Variable Speed Combustion Blower	
- Concert Control™ (24v)	
- High Limit Temperature Control, Manual Reset	
- Water Flow Switch	
- Low Water Cutoff, Manual Reset	
- Condensate Trap	
- Blocked Condensate Switch	
- ASME Temperature & Pressure Relief Valve	
- Temperature & Pressure Gauge	
- Supply, Return & DHW Temperature Sensors	
- Flue Gas Temperature Sensor	
- Modulating Gas Valve	
- Direct Spark Ignition	
- High/Low Gas Pressure Switches, Manual Reset	
- Combustion Air Switch	
- Blocked Vent Switch	
- 120 VAC Only	
- Amp Draw: 7 Amps	
- Category II and IV Venting	
- Individual or Common (Engineered) Vent System	
- CPVC, Polypropylene & Stainless Steel Acceptable *Material	
- Sealed or Room Combustion Air Intake	
- Up to 200 ft equivalent venting / air intake	

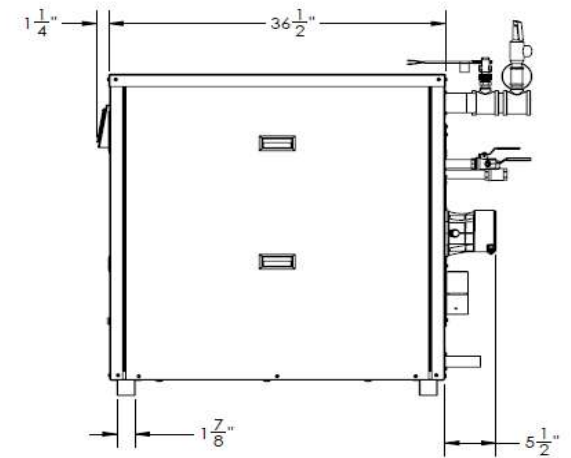
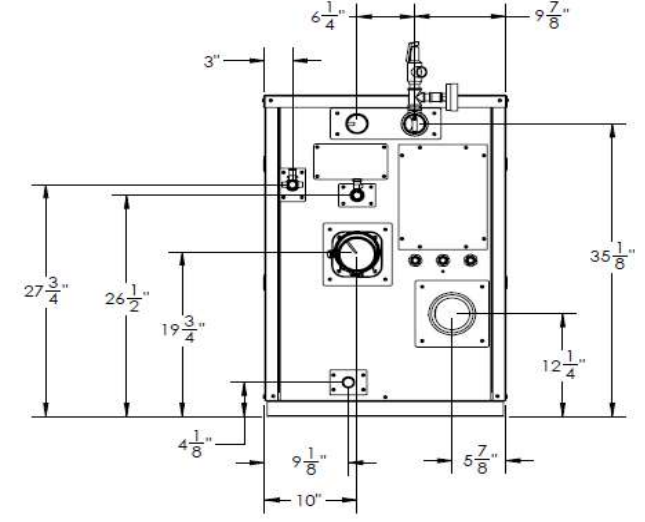
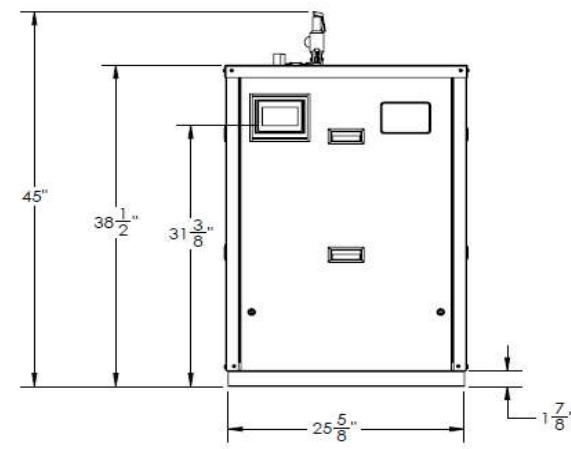
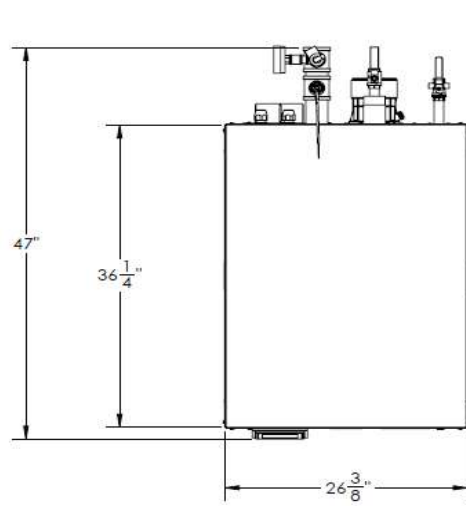

- NOTES:
1. Height dimension is from floor to top of jacket.
  2. Length is from jacket front to jacket rear.
  3. Dimensions shown are for reference only

FLOW REQUIREMENTS		
Water Hardness	Flow (GPM)	Δ P (Ft. Hd)
4 - 12 gpg	33	6.9
12 - 15 gpg	44	11.5

BFITW-500

PROPERTY OF

BRYAN®

783 N Chili Ave | Peru, IN 46970

---

Boiler Technology Leadership Since 1916

www.bryanboilers.com

\* Flue system material shall be capable of continuous operation at 210°F or higher and shall be certified to UL 1738 – venting system for gas-burning appliances cat II, III and IV.