

# RV/EB KNOCK-DOWN STEAM BOILER

FORM 2344  
8/30/2023

---

---

## TABLE OF CONTENTS

---

---

<b>Description</b>	<b>Page</b>
<b>KNOCK-DOWN TYPES AND DEFINITIONS</b>	<b>2</b>
<b>BOILER FOUNDATION &amp; BASE PLACEMENT</b>	<b>2</b>
<b>PRESSURE VESSEL ASSEMBLY</b>	<b>3</b>
<b>FLUE COLLECTOR ASSEMBLY</b>	<b>5</b>
<b>BOILER TUBE INSTALLATION</b>	<b>5</b>
<b>TUBE BAFFLE LOCATION</b>	<b>7</b>
<b>FLUE COLLECTOR INSULATION WRAP</b>	<b>8</b>
<b>JACKET FRAME &amp; PANEL INSTALLATION</b>	<b>9</b>
<b>BURNER &amp; TUBE PANEL INSTALLATION</b>	<b>12</b>
<b>FINAL ASSEMBLY</b>	<b>13</b>
<b>CONNECTIONS</b>	<b>14</b>
<b>CLEANING THE BOILER &amp; SYSTEM</b>	<b>14</b>
<b>START-UP &amp; OPERATION</b>	<b>14</b>
<b>REFRACTORY MIXING INSTRUCTIONS</b>	<b>15</b>
<b>RV/EB TUBE REPLACEMENT (INSTRUCTION #34)</b>	<b>17</b>
<b>RV/EB KNOCK-DOWN BOILER PACKING LIST</b>	<b>19</b>
<b>ILLUSTRATED PARTS LIST</b>	<b>22</b>
<b>B21236 RV/EB STEAM FLUE EXPLODED</b>	<b>26</b>
<b>B21240 KNOCK-DOWN JACKET FRAMEWORK</b>	<b>27</b>
<b>B21235 RV/EB STEAM JACKET EXPLODED</b>	<b>28</b>

# ASSEMBLY INSTRUCTIONS FOR BRYAN “KNOCKDOWN” STEAM BOILERS RV/EB SERIES FORCED DRAFT FIRED

**INTRODUCTION:** Please be assured that your boiler has been completely assembled, inspected and disassembled for shipment at Bryan Steam. These instructions are to help you re-assemble your boiler. The following instructions illustrate the standard RV/EB-Steam construction. Tube panel access will be on the opposite side for RV/EB-Steam reverse construction.

---

## **KD-4**

Indicates the boiler is shipped partially assembled, but constructed to be knocked down as necessary. Downcomers are flanged, refractory floor is not poured, and burner is not installed. Flue collector and jacket frame are tack welded together. Boiler tubes are installed. **Caution:** Assembly is required before boiler can be operated. A welder is required for reassembly, but no ASME Code welding is required. Care should be taken to observe disassembly procedure, since reassembly is exact reverse procedure.

## **KD-5**

Indicates the boiler is completely disassembled at the factory, with jacket and flue collector removed. The tubes and baffles are removed from vessel. The downcomers are removed from the vessel and the upper dome s is bolted to the lower rail for shipment. Components are crated separately (see attached packing list). A welder is required for re-assembly, but no ASME code welding is required.

---

## **1.0 BOILER FOUNDATION & BASE ASSEMBLY**

**1.1** Before uncrating, the boiler location should be prepared. The boiler should be set upon a level concrete floor. If the floor is not level or in good condition, a concrete foundation should be poured.

**1.2** **IMPORTANT:** If the boiler is to be installed directly on a concrete floor where it is important that the floor be kept particularly cool, such as an upper mezzanine, set the boiler upon insulation tile or steel framework so air can circulate underneath. When using insulation tile or steel framework, support the bottom of the boiler base at intervals not greater than 36”.

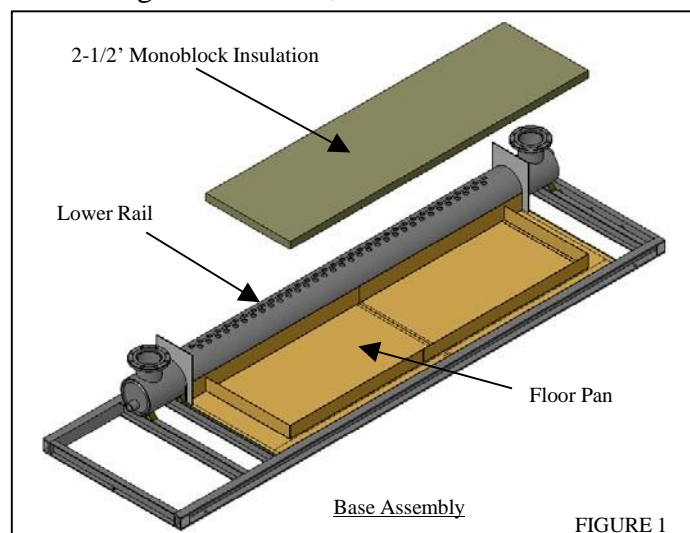

1.3 Place the base assembly on the foundation. **DO NOT INSTALL BOILER ON COMBUSTIBLE FLOORING OR CARPETING.** Make sure that the base is well supported and is level. Simply lay one full layer of monoblock insulation in floor pan. No glue or pins are required. This insulation is 2 ½” thick. See figure 1.

1.4 Refractory is now ready to be mixed according to the instruction on the package. Also refer to page 15-16 for mixing instructions. You will also find one gallon bucket(s) with the boiler, marked “NEEDLES”. These should be mixed with your refractory to help reinforce the refractory and prevent cracking. Once the refractory is mixed, simply pour it over the monoblock insulation. The refractory should be leveled off with the top of the floor pan. See Figure 2. Curing time for the refractory is approximately eight (8) hours.

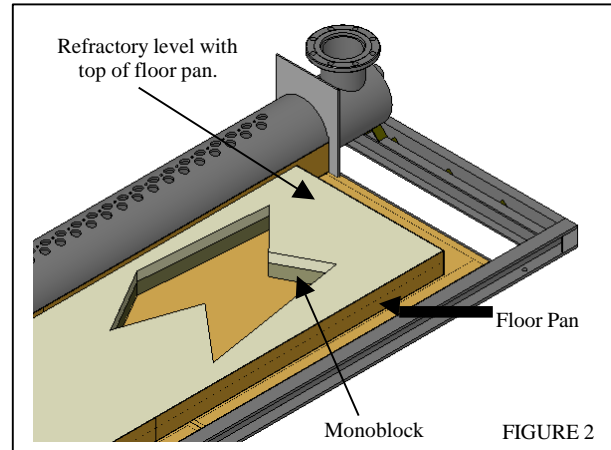

## **2.0 PRESSURE VESSEL ASSEMBLY**

2.1 The downcomers are now ready to be attached to the lower rail. You will notice that the downcomers are color-coded. This is to help you with alignment and assures you that the downcomers are installed exactly the same way they were originally installed at the factory. Simply match the color code on the downcomer to the lower rail. **Make sure to use the flange gaskets between the flanges.** See figure 3.

***Installation Guide For Spiral Wound Gaskets:** The RV/EB series knockdown boiler assembles with four flanged joints located in the downcomers. Proper assembly of these joints will assure long life without leakage. Four spiral wound gaskets come with each unit. These units are shipped disassembled or with temporary gaskets from the factory. **Caution:** Temporary gaskets must be replaced with permanent gaskets before operation. Therefore, the installer will be responsible for assembly. The following guidelines will provide the installer with adequate knowledge to assemble these flanged joints.*

***Flange and Gasket Alignment:** Check assembly drawings for correct orientation of flanges. Verify flange gasket surfaces are clean, parallel to within 1°, and gaskets centered within +/- 1/32". Do not use adhesives on the gasket surfaces. It is important that dry material is in contact with the surface to ensure material flows into imperfections and creates a bond to prevent blowout.*

2.2 Place upper dome on top of the downcomers. See figure 4. Using a level, align the downcomers in the vertical position. Also check the outlet nozzle to make sure it is level.

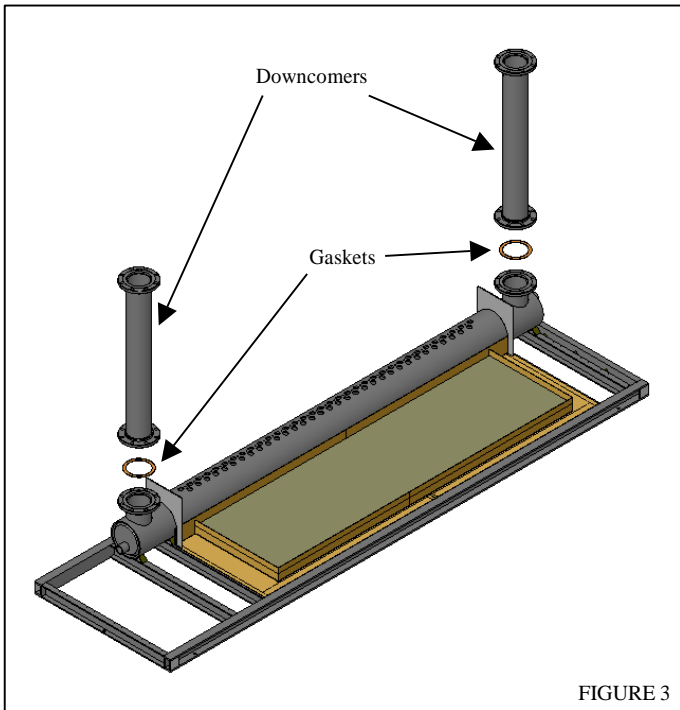

FIGURE 3

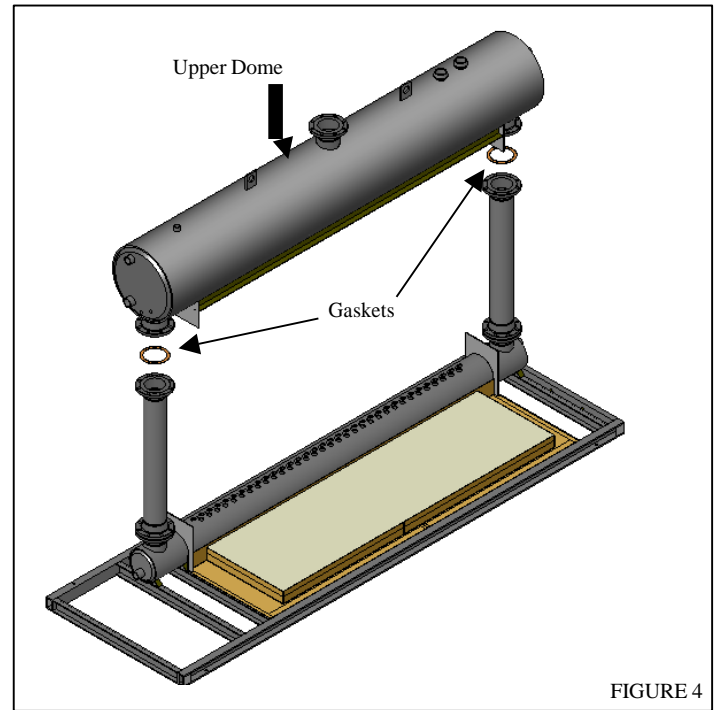
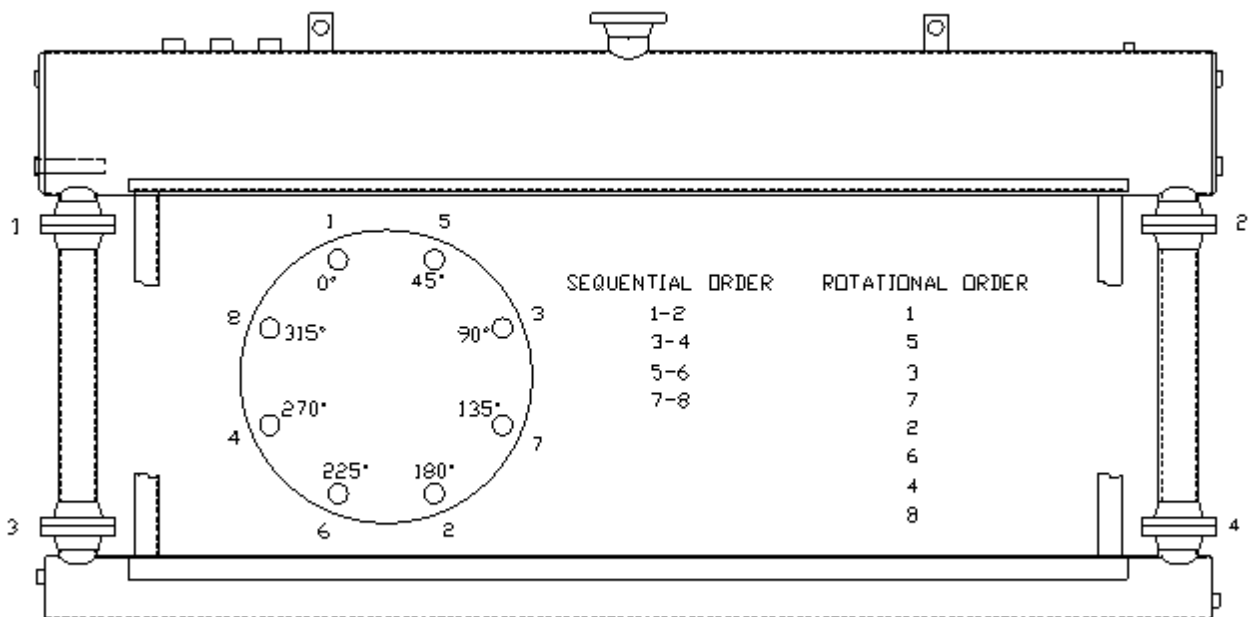

FIGURE 4

**Bolt Tightening:** Bolt and nut threads should be free of dirt and properly lubricated. Finger tighten all bolts on all flange locations marked 1 – 4. Tightening flange bolts will require several passes in a sequential order. Starting with number 1 flange tighten bolts to 75 ft. lbs. using the sequence chart continuing to flanges 2, 3, and 4. Tighten bolts to 150-ft. lbs. for the second pass using the same sequence. Tighten bolts to a final torque of 300-ft. lbs. for the third pass. After boiler is started and heated to operating conditions, bolts will need a final torque of 300-ft. lbs. Jacket and insulation around downcomers will remain off until process is complete.



### **3.0 FLUE COLLECTOR ASSEMBLY**

- 3.1** Install flue collector end filler panel assemblies. You will notice, once again, the color-code system on these pieces. This assures you that once they are installed; they are installed the exact same way they were at the factory. Simply align the colors and factory tack welds. Next, place the tube panel frame in position and tack weld.
- 3.2** Install the front and rear flue collector ends. See figure 7. Once again, notice the color-code system for easy alignment and the tack welds from the factory. It is very important that you **square the front flue collector end with the base frame and tack weld into place.**

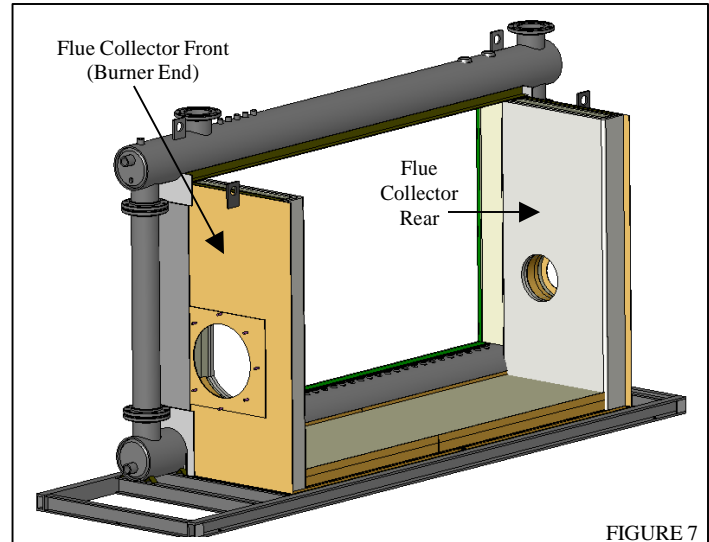
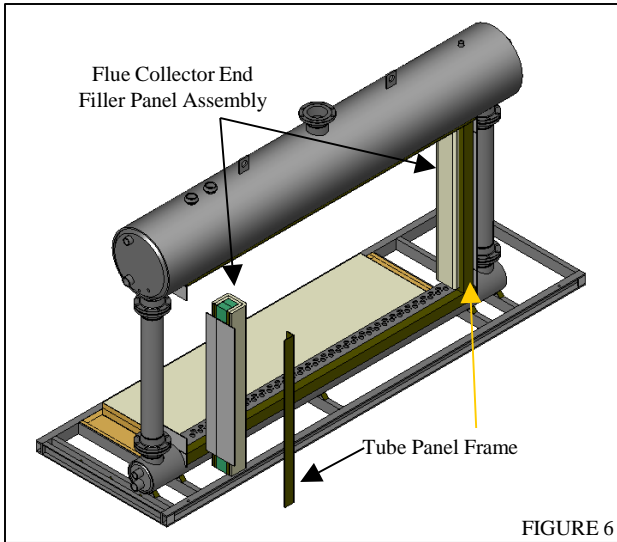

- 3.3 BOILER TUBE INSTALLATION** – See page 17 for attached instruction #34 – Tube Replacement. **NOTE:** It is recommended that a 50-50 mixture of pipe dope and machine oil be mixed together and applied with a small paintbrush to each hole. Use this to lubricate all of the tube holes in the upper dome and lower rail.
- 3.4** Start at the burner end of boiler and install the outside boiler tube in the first tube hole, then install the inside tube. See Figure 7A for tube identification. Repeat the process until all tubes are installed. We recommend installing the tube into the lower rail tube hole first, compress tubing down and insert into upper dome tube hole.
- 3.5** Square up the total tube bank. Tubes must be parallel with the Flue Collector Front and Rear.

**CAUTION:**

**DO NOT OVER-DRIVE THE TAPERED TUBE END FITTINGS.  
THIS IS NOT REQUIRED TO ACHIEVE A GOOD SEAL.**

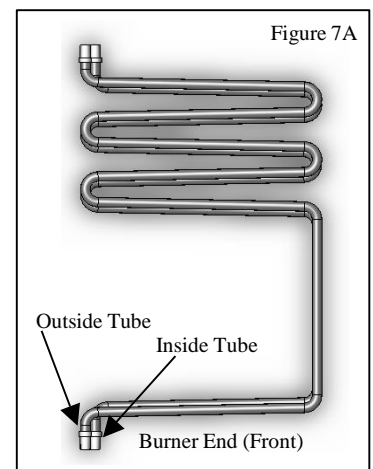

- 3.6** Using a 4 lb hammer and tube driver, drive top of tubes into upper dome. Then drive bottom of tubes into lower rail. Install tube clamps. **NOTE:** *The fittings should be driven until approximately half of the tapered portion of the tube fitting is showing.* Do not use tube clamps to press-fit tubes into position. Breakage of clamps and/or tube studs may result. A tube puller and tube brush is also supplied.

## STOP

This is the best time to test the pressure vessel for any leaks. Close off all openings to boiler and perform a hydrostatic test at the boiler design pressure stamped on the ASME nameplate. Examine all tube fittings and downcomer flanged connections with a flashlight. If there are any leaky tubes, reduce the pressure in the boiler to zero, drive tube fitting slightly further and re-test.

- 3.7** Position horizontal baffle(s) in boiler. See figure 8. Baffle(s) inserts from the flue collector side. It is placed between the first and second pass of the tubes, and at the burner end. On the first horizontal baffle, the vertical break at the burner end goes down. If a second horizontal baffle is required (two baffles for RV800), the vertical break faces the burner end. The baffle lies flat on top of the tubes. The channel break on the sides of the baffle goes up. Refer to SK-1577, page 7, for baffle location.
- 3.8** Install the vertical baffles next. See Figure 8 & 9. These are installed from the tube access panel side. The “T”-shaped baffle is welded to the flue collector top. Two positioning tabs on the first vertical baffle secures the baffle on the tubes. The second vertical baffle is located just inside the up vertical break of the horizontal baffle. It has one set of positioning tabs.
- NOTE:** Vertical baffle placement varies, depending on boiler size. Again refer to SK-1577.

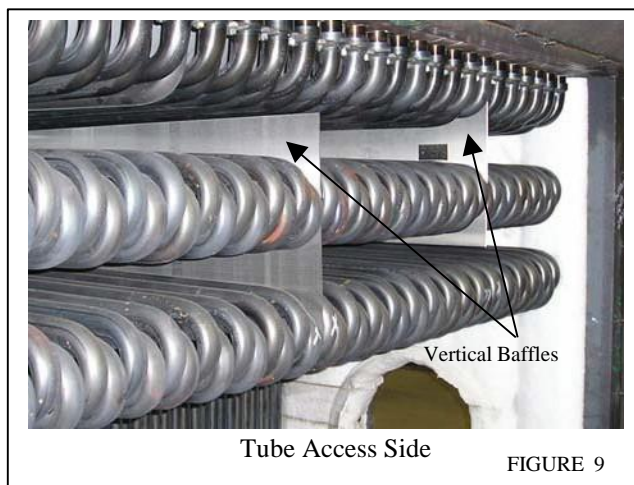
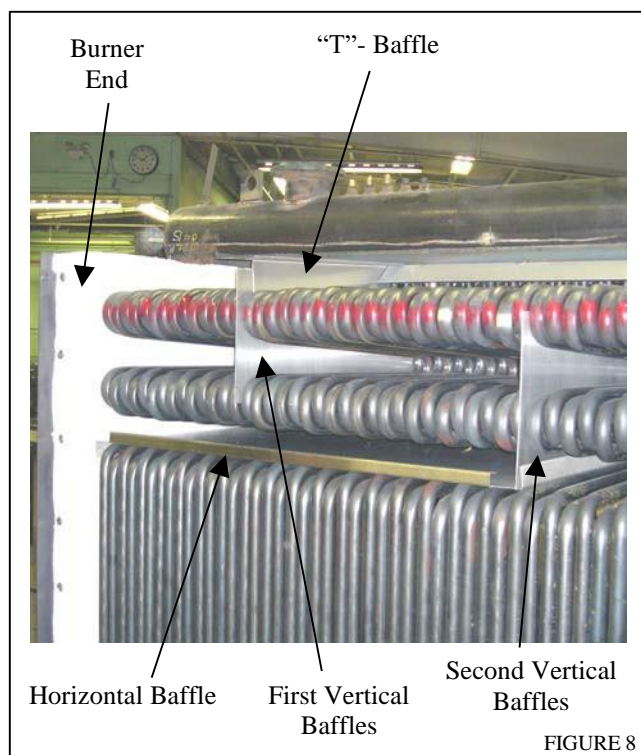

## RV-SERIES TUBE REQUIREMENTS

BOILER MODEL	TOTAL NO OF TUBES IN BOILER	"A" TUBES	"B" TUBES	BAFFLE LOCATION	
				1ST BAFFLE BETWEEN TUBES	2ND BAFFLE BETWEEN TUBES
RV200	27 - 13 INSIDE 14 OUTSIDE	14	13	6 & 7	12 & 13
RV250	33 - 16 INSIDE 17 OUTSIDE	17	16	7 & 8	18 & 19
RV300	41 - 20 INSIDE 21 OUTSIDE	21	20	9 & 10	22 & 23
RV350	47 - 23 INSIDE 24 OUTSIDE	24	23	10 & 11	25 & 26
RV400	55 - 27 INSIDE 28 OUTSIDE	28	27	12 & 13	29 & 30
RV450	61 30 INSIDE 31 OUTSIDE	31	30	12 & 13	32 & 33
RV500	67 33 INDSIDE 34 OUTSIDE	34	33	14 & 15	35 & 36
RV550	75 37 INSIDE 38 OUTSIDE	38	37	16 & 17	40 & 41
RV600	81 40 INSIDE 41 OUTSIDE	41	40	16 & 17	42 & 43
RV700	95 47 INSIDE 48 OUTSIDE	48	47	20 & 21	50 & 51
RV800	109 54 INSIDE 55 OUTSIDE	55	54	24 & 25	58 & 59

- 1 - 6 TUBE PASS NUMBER
- 7 FORCED DRAFT BURNER
- 8 COMBUSTION CHAMBER
- 9 INSULATION
- 10 STACK
- 11 FLUE COLLECTOR
- 12 [ ] HORIZONTAL BAFFLE
- 13 \* 1ST VERTICAL BAFFLE
- 14 \* 2ND VERTICAL BAFFLE
- 15 T - BAFFLE

\* PLACE FROM TUBE PANEL SIDE  
 [ ] PLACE FROM OPPOSITE TUBE PANEL SIDE

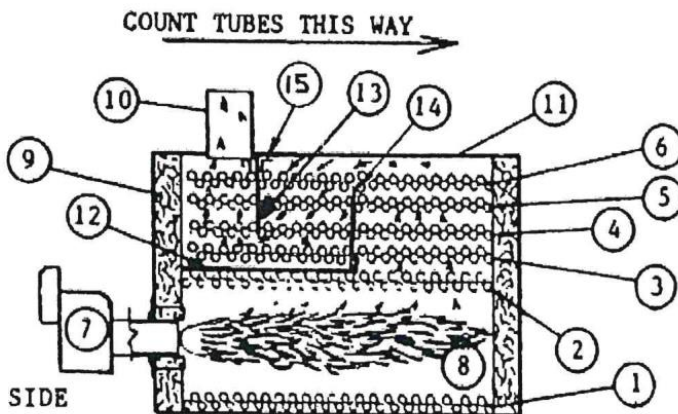

TITLE					SCALE	
TUBE REQUIREMENT CHART RV-SERIES BOILERS					MATERIAL	
1	UNHEATED FACE BAFFLE 10-14.92	5		9	DRAWN BY <i>Steve H.</i>	
2		6		10	DATE <i>2/15/90</i>	
3		7		11	CHECKED BY <i>[Signature]</i>	
4		8		12	APPROVED BY <i>[Signature]</i>	
<b>BRYAN STEAM LLC</b>					DRAWING NUMBER <b>SK-1577</b>	

**3.10** Install the flue collector side panels starting from the burner end. See figure 10. Once again, you will notice the color-code system. This assures you that once the colors are in alignment, the flue collector sides are installed exactly the same way they were installed at the factory. If these parts are installed incorrectly, the colors will not be in alignment. Also note the tack welds from the factory help on this alignment.  
**NOTE:** Make sure that the flue collector side panel insulation is up tight against the rear of the tubes.

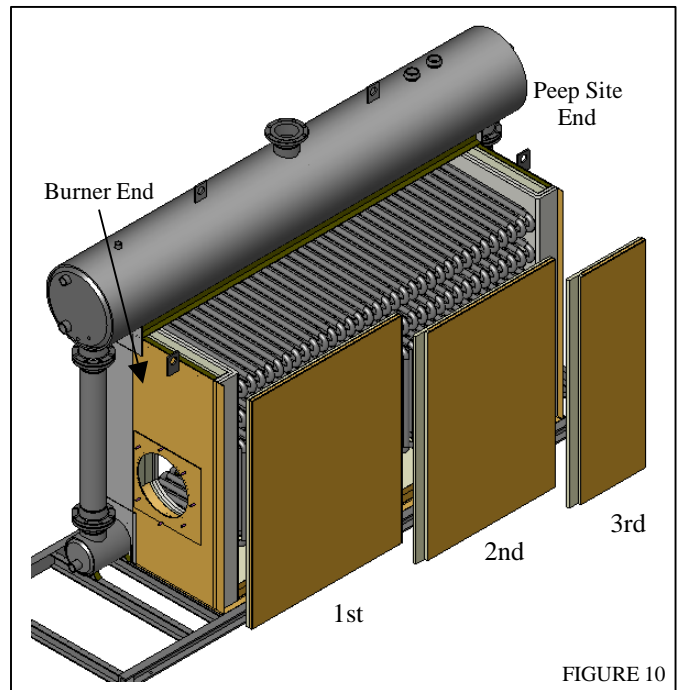

FIGURE 10

**3.11** The flue collector top sits on top of the flue collector box, panels overlapping. The stack goes toward the burner end of the flue box. See figure 11. The “T”-shaped baffle is welded to the bottom of the flue collector top and is located according to the placement of the first vertical baffle. See figure 8 & 9, page 6.

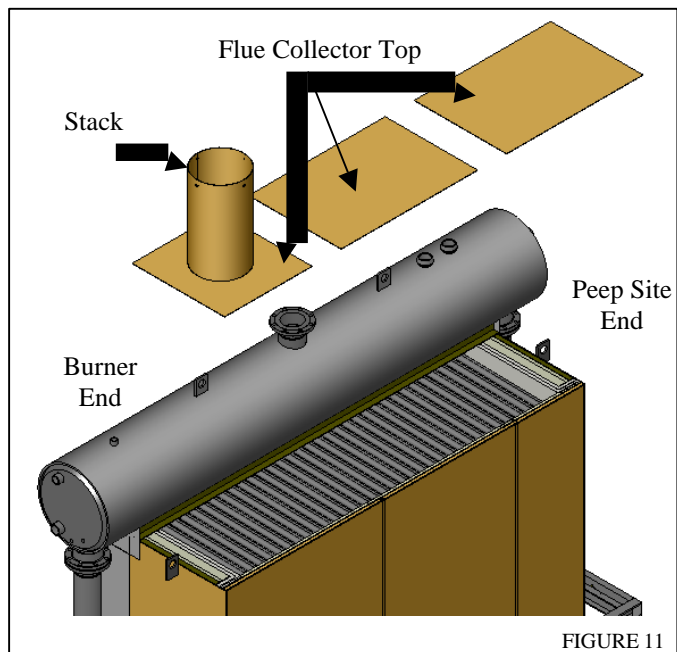

FIGURE 11

**3.12** Check all flue collector panels for proper fit and squareness. Make necessary adjustments and then seal weld all joints. This includes the joints between the flue collector box and the base frame.  
**NOTE:** The combustion chamber is pressurized so all joints must be seal welded. Remove any temporary screws and weld holes shut. **CAUTION:** There can be no pinhole leaks in welds or flue gas will escape into the boiler room.

**3.13** **NOTE:** Flue collector tube access panels are not installed at this time. This is completed after the burner has been installed, step 6.5.

#### **4.0 FLUE COLLECTOR INSULATION WRAP**

**4.1** Install the yellow fiberglass insulation over the entire vessel. The insulation comes in 72” widths. Install a piece of insulation over the upper dome and flue collector top first. See figure 12. Length should be 12” longer than the flue collector top. Let the insulation hang over the sides by 6”. See figure 13. On the tube panel side of the boiler, wrap the insulation over the top of the upper dome, notching around openings and press down on the Insulation weld tabs, illustrated in figure 13, to anchor the insulation. The insulation should only be one layer thick.



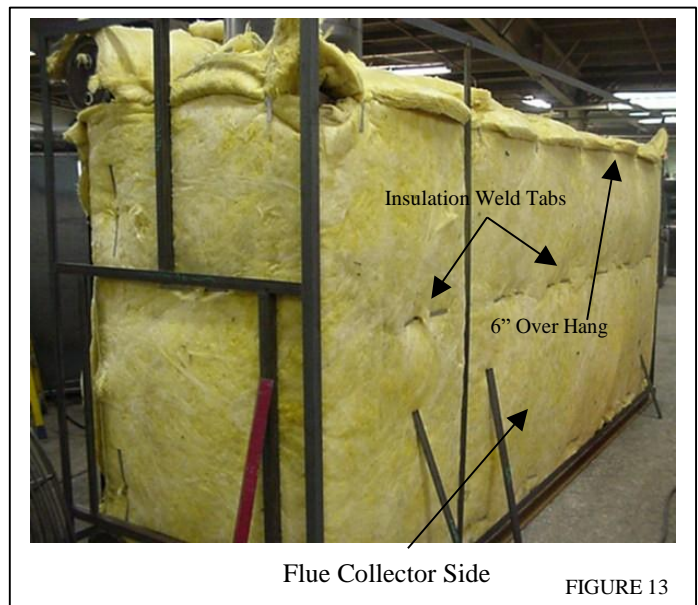

- 4.2 To calculate the length of insulation required to wrap around the flue collector, measure length of flue collector side and add 100". The next step is to wrap the insulation around the burner end, around the flue collector side, and finishing around the peep site end. See figure 13. Tuck 6" overhang, noted in 4.1, behind this section. Use the insulation weld tabs to anchor the insulation to the flue collector parts.

### 5.0 JACKET FRAME & PANEL INSTALLATION

- 5.1 The front and rear jacket framework is installed first. You will notice that each joint in the framework has been given a letter/number. This is to help assist you in putting the proper piece of framework in the correct place. Position the front parts of the jacket frame on the boiler base first. Repeat this procedure for the rear. After front & rear framework is in place, tack weld top angles in place that are depicted in fig 14. **NOTE:** For ease of reassembly, match all letters/numbers and tack welds. Refer to drawing B21240 on page 27.

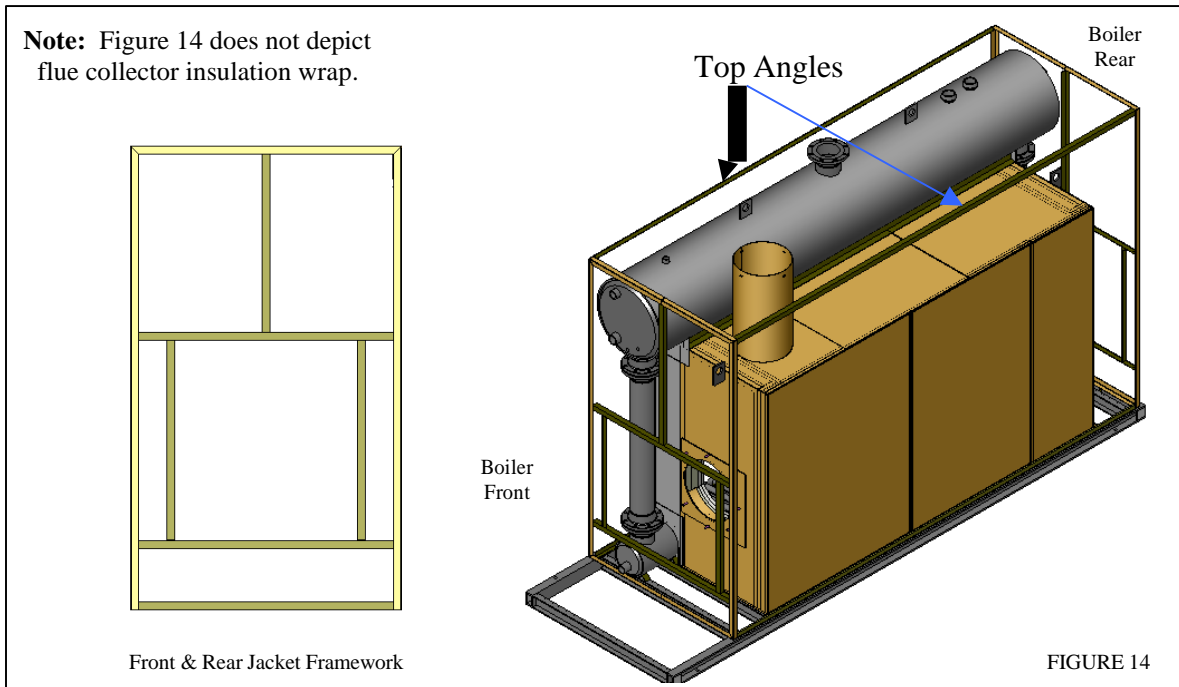

Following are the definitions of the letter on each piece:

- B** the “side” of the boiler (opposite jacket doors)
- D** the “door filler panel” side of the boiler (tube panel side)
- T** the “top” of the boiler
- F** the “front” of the boiler (burner end)
- R** the “rear” of the boiler (peep site end)

These letters will help you to sort out the pieces into stacks until you are ready to assemble that area of the framework.

- 5.2** You now have the basic “box” of the jacket frame on the boiler. See to figure 15. Install jacket filler panel framework on the tube panel side of boiler. Also refer to Drawing B-21240.

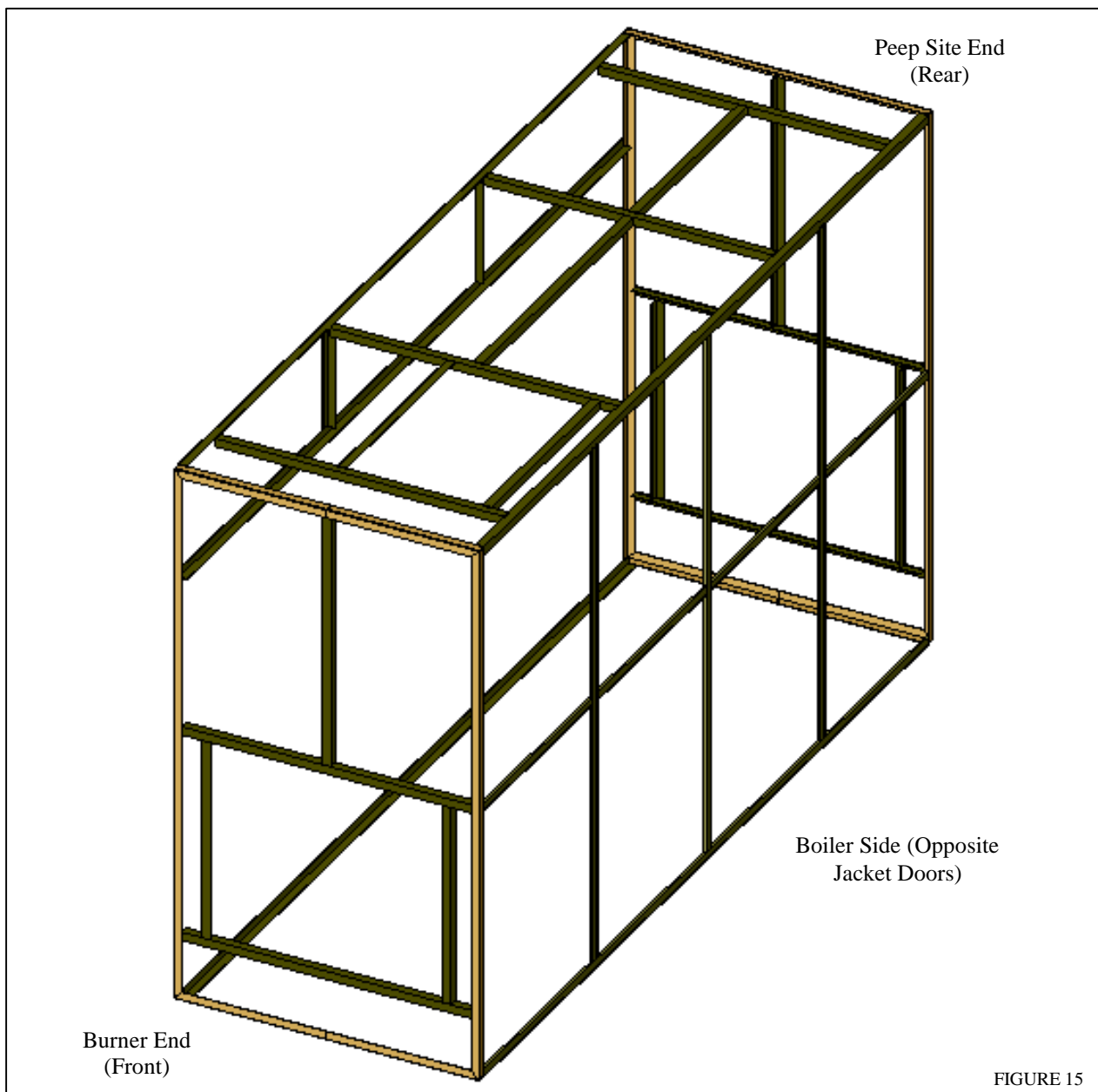

**5.3** After all pieces of the framework have been tacked into place, check the framework to confirm it is square. The crisscross measurement from corner to corner should be the same. Square the boiler side first, the top of the boiler second, and finish on the tube panel side. Remember to refer to drawing B-21240 for a better detail of how to identify the marking system on the jacket frame. This drawing should help explain any questions you might have with the framework and make your job easier.

**5.4** Install jacket panels. See figure 16 and drawing B21235. **NOTE:** Panel configuration varies, depending on boiler type. Panel location is noted on the backside of panels. Primed side goes to the inside. Drill pilot holes with a #26 drill. Attach the panels to the angle iron frame with #8 x 1/2 long self-tapping sheet metal screws. Screws should be spaced about 8" apart. Be sure to measure and mark location to avoid missing framework with screw holes.

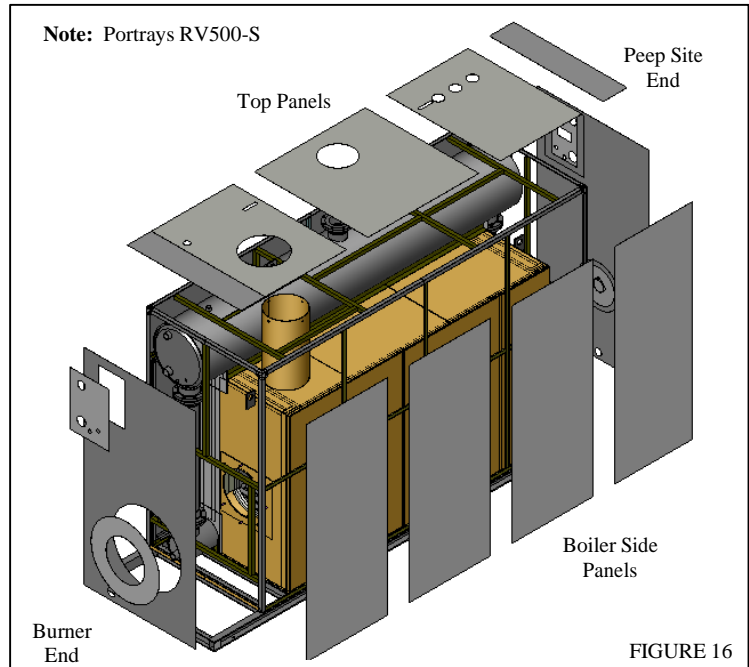

FIGURE 16

**5.5** Position jacket access panel doors on boiler. Start from the peep site end. See figure 17. Once all the panels are in position, center the panels and install filler strips. Use pop rivets to hold these in position until the corner molding is screwed in place. **Note:** After filler strips have been adjusted and installed, jacket access doors will have to be removed to allow for installation of tube panels. Check jacket door insulation to make sure it is glued securely to jacket door.

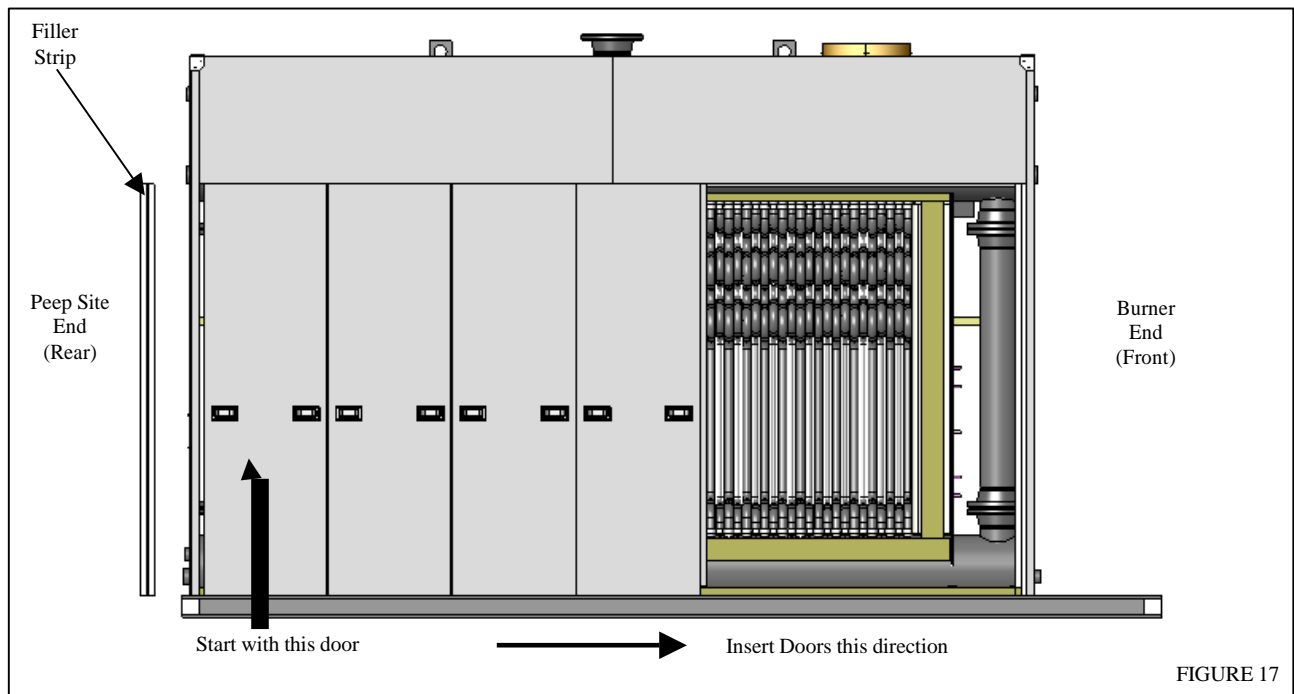

FIGURE 17

- 5.6 Now install all corner moldings. See figure 18. Use the same size screws that were used to install the jacket panels.
- 5.7 Position and attach any overlays that have not been attached at the factory or that have been removed for shipment. Do not install the burner overlay until after the burner is installed.

**6.0 BURNER & TUBE PANEL INSTALLATION**

**NOTE:** A gantry type crane may be required to install burner, gas train, and plug.

- 6.1 If burner is not already attached to burner plug, proceed as follows. Wrap one length of fiberglass insulation rope around the burner head. See figure 19. The rope should overlap by at least 3". Hold rope in position with strips of masking tape. Insert burner into burner plug. Secure the burner to plug with clips and nuts provided.
- 6.2 Position the burner plug level with the hole in flue collector. Wrap one length of fiberglass insulation rope around the burner plug. See figure 19. Again, rope should overlap by at least 3". Now gently guide the plug into the hole.

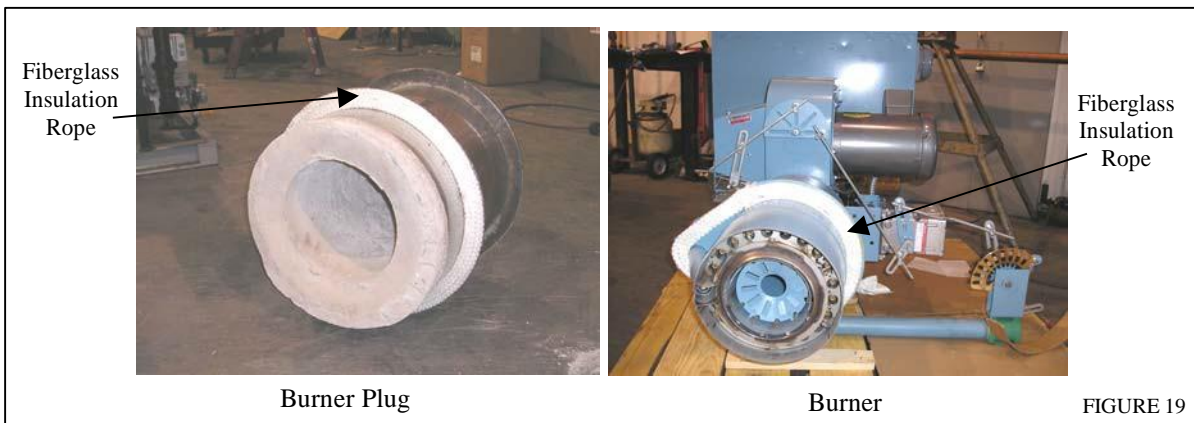
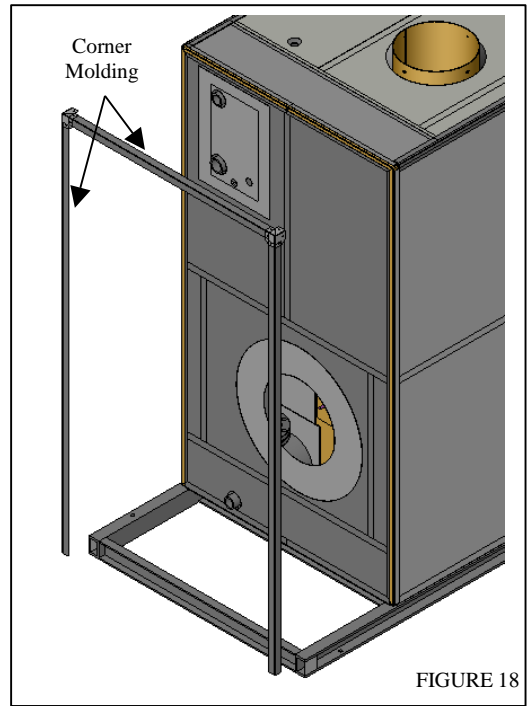

**NOTE:** Make sure that the white blanket insulation is not pushed back. Inspect the blanket from inside the boiler. Secure the plug with clips and nuts provided. There will be a gap around the burner plug when it is installed in the flue collector end. This gap must be packed tight with Inswool (white blanket). See figure 20. Extra blanket is provided for you to do this. **The burner plug MUST be properly packed with white blanket insulation or the manufacturers warranty is null and void.** After it is packed, put a thin layer of T-36 cement around the seam you just packed. See figure 21. The cement is provided from the factory in a bucket marked "T-36".

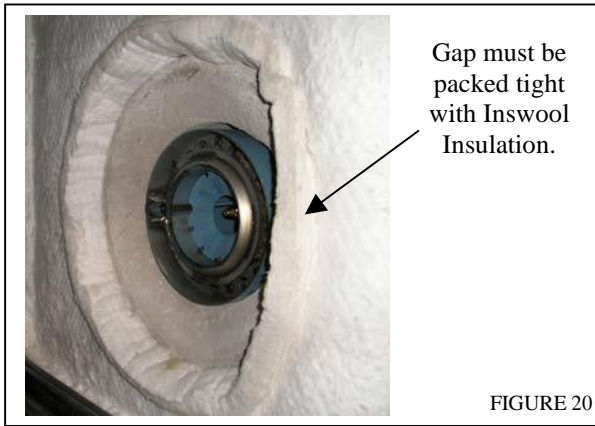

FIGURE 20

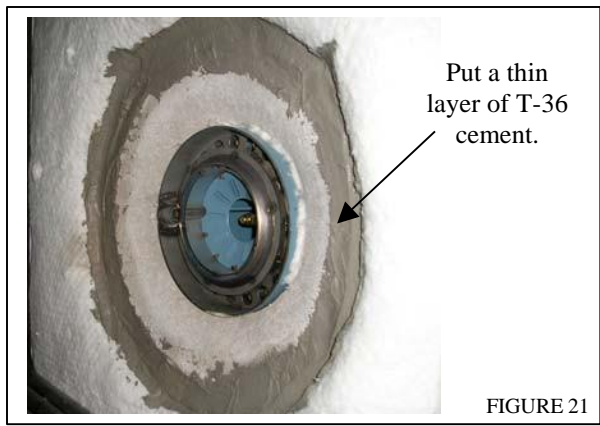

FIGURE 21

**6.3** Install peep site plug and fiberglass insulation rope in rear flue collector. Secure plug with clips and nuts provided. Install peep site lens, if not already installed. **NOTE:** Use the same installation procedure that was used on the burner plug in Section 6.2.

**6.4** Glue the rope gasket to the tube panel frame. This gasket goes on the inside edge of the tube panel framework. Use the glue that is provided.

**6.5** Install the tube panels. See Figure 22. Start from the peep site end. Install rope gasket between each panel. Install tube panel clamp angles. Do not tighten the nuts and bolts until all panels are in place. **NOTE:** The hinged panel will be at the burner end. Once all panels are in place, tighten all bolts and nuts.

**6.6** Finish jacket installation by installing jacket access panel doors. Start from the peep site end.

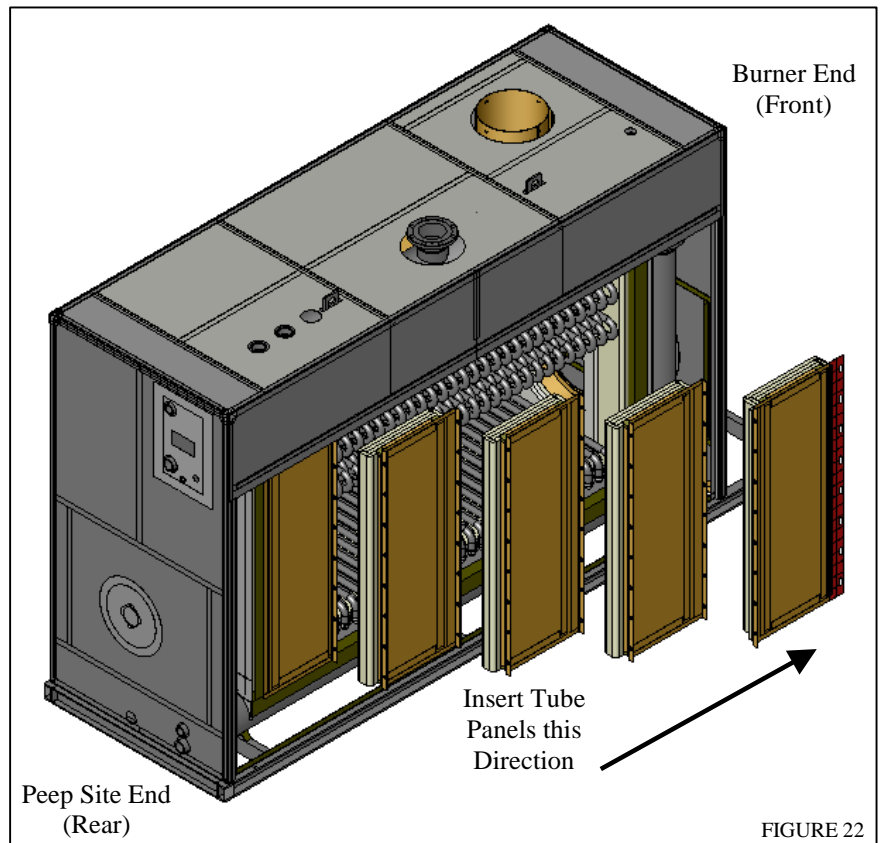

FIGURE 22

## **7.0 FINAL ASSEMBLY**

**7.1** Install boiler control box/panel on front jacket panel, above the burner. The control box/panel is already pre-wired from the factory. There will be pre-drilled holes in the front jacket panel for you to anchor the control box/panel.

- 7.2 Install your low water cutoff(s). Refer to the dimensional provided with these instructions to see where the low water cutoff(s) should be installed. This control must be wired back to the control box/panel.
- 7.3 Install controls and temperature control sensor bulbs into immersion wells. Replace retaining clips.
- 7.4 Install the relief valve(s) in the proper top couplings. Install the combustion chamber drainpipe in the proper coupling. Again refer to the dimensional provided with these instructions to see where the proper locations are for these accessories.
- 7.5 Re-wire any items to the force draft burner that may have been removed during installation of any other components as required.

NOTE: Refer to the wiring diagram(s) provided with the boiler.

### **8.0 CONNECTIONS**

- 8.1 Refer to “Installation Operation Service Manual”.
- 8.2 Connect all fuel piping and electrical connections as required. Refer to Section 1.5 in “Installation Operation Service Manual” for recommended practice.
- 8.3 Perform pressure test of boiler and fuel piping as directed in “Installation Operation Service Manual” and in accordance with applicable codes and insurance requirements.
- 8.4 Be certain that proper provision has been made for combustion air and flue gas venting as directed in Section 1 of “Installation Operation Service Manual”.
- 8.5 Make certain that the boiler room is always at a neutral or positive pressure, relative to outdoors, and that the stack is properly installed and designed to avoid downdrafts. The boiler cannot function in a negative pressure room or under conditions of sustained downdrafts without the use of carefully designed and selected mechanical equipment.

### **9.0 CLEANING THE BOILER & SYSTEM**

- 9.1 Refer to Section 3 in “Installation Operation Service Manual”.
- 9.2 Care must be taken on old systems to clean all piping and system components to remove all sediment. Be certain that there are no leaks and that the air removal and expansion tank system are functional.

### **10.0 START-UP AND OPERATION**

- 10.1 Refer to Section 2 in “Installation Operation Service Manual”. **IMPORTANT: This equipment should only be started and adjusted by a qualified burner technician.** Combustion data should be taken and recorded on the start-up report form supplied in the boiler manual. This is essential for safe and proper operation of this boiler.



## Technical Information

---

### GENERAL GUIDELINES - CASTING RESCO INSULATING CASTABLES

#### A. STORAGE:

1. Resco Insulating Castables are packaged in moisture resistant bags; however, they should be stored in a dry place free from excess dampness. Storage on dry concrete, asphalt, or other impervious surface will prevent moisture from the ground condensing under the plastic pallet cover and wetting the bags of material, which may result in loss of strength.

#### B. PREPARATION:

1. Use clean tools and equipment. Contamination can affect setting and strength of castables.
2. Waterproof all forms and surfaces. Mold release agents may be used.
2. Use only clean water suitable for drinking.
3. A paddle-type mechanical mixer is preferred.
4. For best results, material and ambient temperatures should be 60-85°F (16-29°C) during mixing, placing, and curing.

#### C. MIXING:

1. Mix only as much castable as can be placed immediately. Under ideal conditions, 20 minutes is the maximum placement time. Material left in pails or mortar box may develop a "false" set making it difficult to properly place.
2. Pre-dampen mixer prior to mixing first batch.
3. Add the dry material to the mixer. Then, quickly add the minimum amount of specified water to the mixer while mixing.
4. Insulating castables should be mixed for no more than two minutes after the water is added to the mix. Additional water should only be added after the two minute mixing and a visual inspection of the mix. Stay within the recommended water levels for the particular product.
5. If metal fibers are to be added, they should be slowly and uniformly distributed into the mixer during the beginning of the two minute mixing interval
6. Recommended wet mix temperature is 60-85°F.

## Technical Information

---

### D. PLACING:

1. External vibrators are not recommended. Internal vibrators capable of a frequency of 10,000 vpm or greater are recommended to densify conventional castables, but vibration should be minimized for insulating castables to avoid excessive densification.
2. Be careful not to over vibrate. Stop when small bubbles no longer appear on the surface.
3. Don't overwork or excessively trowel the surface. A smooth surface inhibits moisture removal during curing and drying by bringing fines to the surface. Do not burn out wood forms.

### E. CURING:

1. The cast material should cure for a minimum of 24 hours before drying can commence. Use wet burlap, plastic sheet or resin based curing compound. Water spraying should be avoided.
2. The cast material should not be disturbed, allowed to freeze, or be heated above 120°F during the curing stage.

### F. EXTREME WEATHER PRECAUTIONS

#### 1. Extreme Cold Weather:

- Keep the material, and installation area above 60°F (16°C) during installation and 24 hour curing period.
- Do not allow lining to freeze during 24-hour curing period. After the curing period, the lining may be subjected to freezing conditions, however, the castable should be at least 60°F (16°C) before dry out is started.

#### 2. Extreme Hot Weather:

- Keep the material, and installation area below 85°F (29°C) during installation and 24 hour curing period. Elevated temperatures may reduce working time, and cause cracking due to surface dryout.
- Store the dry castable in a cool area prior to mixing.
- Use cold water, less than 45°F (7°C) during mixing.
- Shade or water spray the exterior surface of the unit.





# Bryan Boilers

## Removal and Replacement of Flexible Water Tubes

Instruction 34

(1/97)

Follow this easy step-by-step procedure to remove or replace the flexible water tubes in Bryan Boilers. This process requires no rolling or welding. Follow the steps as outlined for the most efficient and least time consuming procedure.

**CAUTION: GOGGLES OR SAFETY GLASSES SHOULD BE WORN TO PREVENT INJURY.** Before removing tube(s), boiler must be completely drained of water. If boiler outlet and return are equipped with shutoff valves, close both to avoid draining the entire system.

TOOLS REQUIRED	
<b>Hammer</b>	
A.	For 3/4" and 1" tubes, two pound hammer
B.	For all 1 1/2" tubes, four pound hammer
<b>Tube Puller (Available from Bryan)</b>	
A.	For 3/4" tubes, number 4 puller
B.	For 1" tubes, number 2 puller
C.	For 1 1/2" tubes, number 3 puller
<b>Tube Driver (Available from Bryan)</b>	
A.	For 3/4" and 1" tubes, number 1 driver
B.	For 1-1/2" tubes, number 2 driver
<b>Nut Wrench - 3/8"</b>	

TUBE ORDERING INFORMATION	
<b>For Bryan Boiler Series</b>	Order tubes by configuration
<b>F, D and HED Series</b>	Tubes are long or short. Outside is long, inside is short.
<b>L Series</b>	Tubes are right hand or left hand. (facing burner end)
<b>LM, AB, RV and RW Series</b>	Tubes are inside or outside

### PREPARATION

Begin by removing the insulated jacket side panels or doors, exposing the inner tube access panels. On some models (L, LM and RW Series) tube access is from both sides. On each end of every tube is a welded steel tapered ferrule which is driven into tapered holes in the upper and lower steel headers.

## REMOVAL OF TUBES



1. Remove lower tube clamps. On most models a stud and clamp are required over the steel ferrule. Remove the retaining nut and clamp before attempting to remove the tube(s). To facilitate removal, you may need to soak with good penetrating fluid. ←

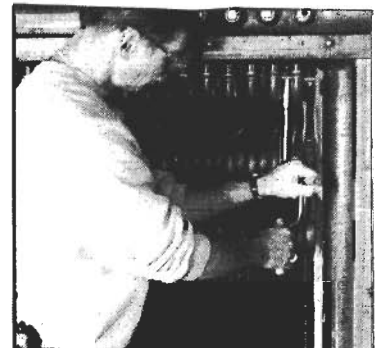

2. Remove upper tube clamps. Follow the same procedure as step one. →



3. Loosen tube ferrules. Strike the side of the tube ferrule two or three times with a hammer to help loosen the tube ferrule in the upper and lower header. ←



4. Pull lower tube ferrule (outer row of tubes). Drive the tube puller wedges under the lip of the tube ferrule with several blows of the hammer on the end of the handle. Alternate with downward blows to lift the tube ferrule. Hold the leverage and repeat to drive the wedge further. →



5. Clear tube Ferrule from the header. Continue driving wedge under and levering fitting up  
← until it pops the end of the tube free from the hole in the header.

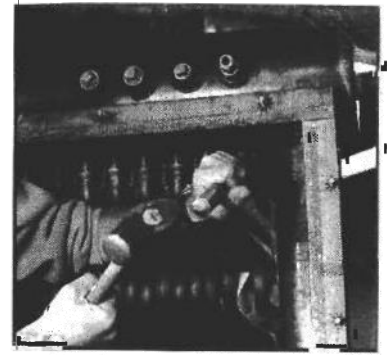

6. Pull upper tube ferrule. Repeat the procedure to pull the tube ferrule of the same tube from the upper header. →

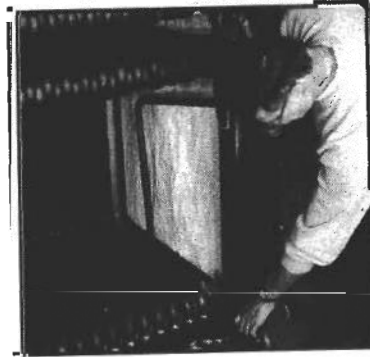

7. Remove outer row tube. Remove the tube and repeat with other outer row tubes to gain access to rear tubes. If a tube leak occurs in an inner tube, two adjacent outer tubes must be removed to access the inner tube for removal. ←

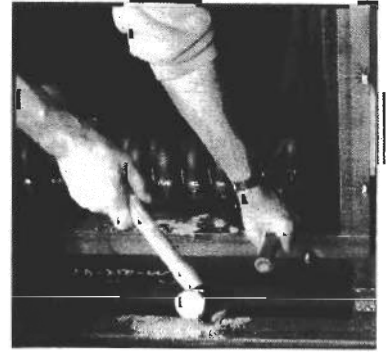

8. Pull inner row tube ferrules. Repeat the procedure in steps four through seven to remove inner tube or tubes. →

### REPLACEMENT OF TUBES

Before placing a new tube into the headers, clean the holes by wiping gently with emery cloth to be sure there are no burrs. If replacement tube has been sitting for a long period of time and shows rust, repeat the cleaning procedure on the tube ferrule. With a small brush, apply a thin coating of gray pipe dope around the inside of the hole and all around the tube ferrule.



9. To replace tubes, start with the inner tube. Insert the lower tube ferrule in the bottom header first then the top tube ferrule in the top header. Replace all tubes before driving.



10 & 11.

Drive the tube ferrules until they seat. With the driver tool positioned on the ring, strike the end of the driver with the hammer three or four blows. **DO NOT DRIVE THE FERRULE DOWN TO THE RING.** Before the ring reaches the header, after three or four good hits, you will hear a solid hit. This indicates the tube is seated.

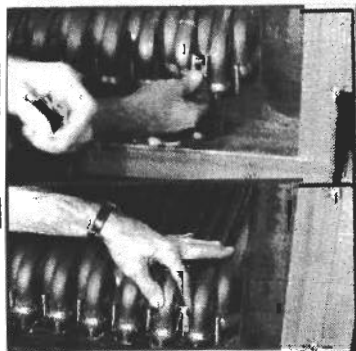

12. Replace tube clamps. If your unit is equipped with studs and clamps, reinstall the tube clamps and secure them with nuts. Tighten the nut only until snug. Do not try to compress the ferrule into the holes with the clamps, because the clamps might break or the studs might shear.

### REFILL THE BOILER

Refill the boiler with water. Fill until pressure is slightly under the relief valve set pressure. Inspect all tube ferrules for leaks. If the tube(s) you replaced leaks, reduce the pressure in the boiler to zero, then strike the fitting once or twice with the driver and hammer as shown in steps ten and eleven above. After inspection, replace the tube access panels and jacket access doors.

# RV/EB SERIES KNOCKDOWN PACKING LIST

ORDER NO. \_\_\_\_\_ MODEL NO. \_\_\_\_\_ SERIAL NO. \_\_\_\_\_

PACKING COMPLETE, INSPECTED AND APPROVED BY:

(AT LEAST TWO SIGNATURES REQUIRED)

LEADMAN _____	DATE _____
FOREMAN _____	DATE _____
Q.C. INSPECTOR _____	DATE _____

**ATTENTION:**

- 1) ONLY ONE BOILER TO BE KNOCKDOWN AND CRATED AT A TIME.
- 2) JACKET FRAME AND FLUE COLLECTOR TACK WELDS TO BE GROUND LOOSE TO DISASSEMBLY. NEVER USE HAMMER OR BEND METAL TO BREAK TACKS WELDS LOOSE. THIS CAUSES MIS-ALIGNMENT IN FIELD DURING REASSEMBLY.
- 3) THE FOLLOWING CHART INDICATES THE NUMBER OF BAGS OF REFRACTORY AND THE NUMBER OF MONOBLOCK PANELS REQUIRED FOR SHIPMENT PER MODEL.

MODEL	BAGS	PANELS	RV-300	4	3	RV-450	6	5	RV-600	8	6
RV-200	3	2	RV-350	5	4	RV-500	7	5	RV-700	9	7
RV-250	3	3	RV-400	5	4	RV-550	7	6	RV-800	11	8

- |  |       |       |      |  |
|--|-------|-------|------|--|
|  | PROD. | FORM. | Q.C. |  |
|--|-------|-------|------|--|
- 4) 

--	--	--

 EVERY JOINT ON JACKET FRAME TO BE NUMBERED ACCORDING TO DRAWINGS B-21239 (WATER), AND B-21240 (STEAM). (B=BACK SIDE OF BOILER, D=DOOR PANEL SIDE, T=TOP OF BOILER, F= FRONT OF BOILER, R=REAR OF BOILER)
  - 5) 

--	--	--

 COLOR CODING COMPLETE, DOWN COMERS TO DOME AND RAIL, FLUE COLLECTOR END PANELS, SIDES AND TOP, SIDE TUBE PANEL FRAME ANGLES. (USE DIFFERENT COLORS FOR FRONT, REAR AND SIDE)
  - 6) 

--	--	--

 ALL JACKET PANELS ARE MARKED ON BACK SIDE INDICATING APPROXIMATE LOCATION.
  - 7) 

--	--	--

 ALL PAINTED PARTS TO BE SEPARATED BY PAPER OR CARD BOARD WHEN CRATING
  - 8) 

--	--	--

 ALL LOOSE PARTS MUST BE SECURED IN CRATES TO PREVENT DAMAGE DURING SHIPMENT.
  - 9) 

--	--	--

 CRATES ARE TO BE INITIALED BY FOREMAN OR Q.C. INSPECTOR WHEN CLOSED.

**CRATE NO. 1**

INITIAL AT LEAST TWO ENTRIES

PROD.	FORM.	Q.C.	DESCRIPTION	REMARKS
			BOILER BASE & FRAME (UPPER DOME HEADER BOLTED TO LOWER RAIL HEADER)	
			TWO DOWNCOMERS (COLOR CODED)	
			FOUR NEW GASKETS FOR DOWNCOMERS (METAL WOUND FOR HIGH PRESSURE)	
			72" ROLL OF YELLOW INSULATION	

**CRATE NO. 2**

			BOILER TUBES, LIST NUMBER OF TUBES SHIPPED	
			TUBE CLAMPS AND NUTS (PLACE IN SEALED BUCKET OR CAN INSIDE CRATE)	
			PIPE LUBRICANT (FOR USE IN TAPERED TUBE HOLES)	
			ONE TUBE DRIVER	

**CRATE NO. 3**

			ASSEMBLY INSTRUCTIONS & KNOCK DOWN VIDEO (MARK CRATE "VIDEO INSIDE")	
			IM-11 INSTALLATION, OPERATION & SERVICE MANUAL, WIRING & DIMENSIONAL	
			FLUE COLLECTOR ENDS	
			HORIZONTAL TUBE BAFFLES	
			1st VERTICAL TUBE BAFFLE	
			2nd VERTICAL TUBE BAFFLE	
			T BAFFLES	
			FLANGE BOLTS AND NUTS FOR DOWNCOMERS	
			MONO BLOCK INSULATION, LIST NUMBER OF PANELS SHIPPED	
			BURNER CLAMPS AND NUTS	
			BURNER PLUG	
			BURNER PLUG CLAMPS AND NUTS	
			PEEP SITE PLUG (REAR END)	
			PEEP SITE PLUG CLAMPS AND NUTS	
			PEEP SITE PLUG FIBERGLASS INSULATION ROPE	
			DRAFT DIVERTER (IF REQUIRED) LIST DIAMETER SHIPPED _____ DIA.	
			BAROMETRIC (IF REQUIRED) LIST DIAMETER SHIPPED _____ DIA.	

**CRATE NO. 4**

			FLUE COLLECTOR TOP	
			FLUE COLLECTOR SIDE PANELS (BACK)	
			COMPLETE JACKET FRAME (NUMBERED)	
			BAGS OF REFRACTORY (KAST-O-LITE #22), LIST NUMBER OF BAGS SHIPPED	
			BUCKET(S) OF NEEDLES FOR REFRACTORY (MARK BUCKET "NEEDLES")	
			ONE BUCKET OF T-36 CEMENT	

**CRATE NO. 5**

			TUBE ACCESS PANELS, LIST NUMBER OF PANELS SHIPPED	
			TUBE ACCESS PANEL ROPE GASKET	
			SIDE TUBE PANEL FRAME ANGLES WITH STUDS	
			TUBE PANEL CLAMP ANGLES FOR SECURING TUBE PANELS WHEN INSTALLED	
			TUBE PANEL NUTS, WASHERS AND BOLTS	
			TUBE PANEL SPACER FOR HINGE PANEL	

**CRATE NO. 6**

			BURNER (FRONT) END JACKET	
			BURNER (FRONT) END JACKET OVERLAYS	
			PEEP SITE (REAR) END JACKET	
			PEEP SITE JACKET OVERLAY (REAR END)	
			PEEP SITE SWINGING COVER	
			EXTRA INSULWOOL FOR BURNER PLUG AND PEEP SITE PLUG	
			JACKET TOP PANELS	
			JACKET TOP FILLER PANELS AND OVERLAYS	
			UPPER FILLER PANELS	
			JACKET SIDES (BACK)	
			JACKET DOORS, LIST NUMBER SHIPPED _____.	
			JACKET TRIM (CORNERS, CORNER MOLDINGS)	
			JACKET SCREWS (BAGGED)	
			TOUCH UP PAINT (GRAY)	
			CONTROLS (HI LIMIT, OPERATOR) AND SENSOR BULBS	
			CONTROL BOX / PANEL (PRE-WIRED)	
			RELIEF VALVES (IF REQUIRED BUSHINGS)	
			GAUGE GLASS SET (IF REQUIRED)	
			FLOAT LOW WATER CUT OFF (IF REQUIRED PRE-PIPED)	

			PROBE TYPE LOW WATER CUT OFF	
			SYPHON ASSEMBLY (IF REQUIRED PRE-PIPED)	
			BLOW DOWN ASSEMBLY (IF REQUIRED PRE-PIPED)	
			COMBUSTION CHAMBER DRAIN PIPE	
			PRESSURE / TEMPERATURE GAUGE	
			DRILL BITS	
			GLUE (ONE QUART) FOR ROPE GASKET	
			HEAT CONDUCTIVE COMPOUND FOR AQUASTATS	
			ONE TUBE BRUSH	
			ONE TUBE PULLER	

**CRATE NO. 7**

			BURNER (PRE-WIRED)	
			BURNER MANUAL	
			BURNER GAUGE (INSTALLED)	
			AIR SILENCER (IF REQUIRED)	
			BURNER AND BURNER PLUG ROPE GASKET	
			REMOTE OIL PUMP (IF REQUIRED PRE-PIPED)	
			PILOT TUBE	
			GAS TRAIN	

EFF. DATE 8/26/05

REPL. NEW

# ILLUSTRATED PARTS LIST

FORM: 2360

PAGE: RV - S - 1

FOR RV/EB-SERIES, STEAM BOILERS RV350 - RV800

---

## ORDERING INSTRUCTIONS

WHEN ORDERING PARTS FOR YOUR BRYAN BOILER OR HEATER,  
BE SURE TO INCLUDE THE FOLLOWING INFORMATION:

- |   |                          |
|---|--------------------------|
| 1. QUANTITY OF ITEMS REQUIRED                   | 4. BOILER MODEL NUMBER   |
| 2. PART NUMBER FROM THIS PARTS LIST (IF LISTED) | 5. BOILER SERIAL NUMBER  |
| 3. DESCRIPTION OF PART                          | 6. SHIPPING INSTRUCTIONS |

## EXAMPLE

PLEASE FORWARD TO US:

<u>QTY.</u>	<u>PART NO.</u>	<u>DESCRIPTION</u>	<u>FOR MODEL</u>	<u>BOILER SERIAL NO.</u>	<u>SHIP VIA</u>
5	38101	Boiler Tubes	RV450	12345	Freight Truck

BRYAN BOILERS  
 783 N. CHILI AVE. \* PERU \* INDIANA \* 46970  
 PHONE: 765-473-6651 \* FAX: 765-473-3074  
 E-MAIL: bryanboilers@iquest.net \* INTERNET: <http://www.bryanboilers.com>

**RV/EB  
SERIES**

**FORCED DRAFT STEAM**

ITEM	DESCRIPTION	RV350-S		RV400-S		RV450-S		RV500-S		RV550-S		RV600-S		RV700-S		RV800-S	
		REQ	PART NO.	REQ	PART NO.	REQ	PART NO.	REQ	PART NO.	REQ	PART NO.	REQ	PART NO.	REQ	PART NO.	REQ	PART NO.
1	PRESSURE VESSEL - (With Tubes)-15#	CONSULT FACTORY															
1	PRESSURE VESSEL - (With Tubes)-150#																
<b>BOILER BASE ASSEMBLY</b>																	
2	Boiler Base Assembly	1	400314.350	1	400314.400	1	400314.450	1	400314.500	1	400314.550	1	400314.600	1	400314.700	1	400314.800
	Floor Insulation Block	1	300910.350	1	300910.400	1	300910.450	1	300910.500	1	300910.550	1	300910.600	1	300910.700	1	300910.800
	Refractory Cement (in pounds)	200	24554.1	236	24554.1	259	24554.1	286	24554.1	319	24554.1	346	24554.1	400	24554.1	465	24554.1
<b>STEAM BAFFLE ASSEMBLY</b>																	
3	Steam Baffle Assembly	1	400336.305	1	400336.400	1	400336.450	1	400336.500	1	400336.550	1	400336.600	1	400336.700	1	400336.800
<b>BOILER TUBE ASSEMBLY</b>																	
4	Boiler Tube Inside Assembly	47	38101	55	38101	61	38101	67	38101	75	38101	81	38101	95	38101	109	38101
5	Boiler Tube Outside Assembly	47	38100	55	38100	61	38100	67	38100	75	38100	81	38100	95	38100	109	38100
	Boiler Tube Studs	23	25184	27	25184	30	25184	33	25184	37	25184	40	25184	47	25184	54	25184
	Tube Clamp	23	23622	27	23622	30	23622	33	23622	37	23622	40	23622	47	23622	54	23622
	Tube Clamp Nut	23	25114	27	25114	30	25114	33	25114	37	25114	40	25114	47	25114	54	25114
<b>TUBE BAFFLE ASSEMBLY—</b>																	
6	Tube Baffle Burner End Vertical	1	400315.350	1	400315.400	1	400315.450	1	400315.500	1	400315.550	1	400315.600	1	400315.700	1	400315.800
7	Tube Baffle Peepsite End Vertical	1	400316.350	1	400316.400	1	400316.450	1	400316.500	1	400316.550	1	400316.600	1	400316.700	1	400316.800
8	Tube Baffle Horizontal	1	300910.350	1	300910.400	1	300910.450	1	300910.500	1	300910.550	1	300910.600	1	300910.700	2	300910.8
9	Tube Baffle Short Antibypass	1	300907.17	1	300907.20	1	300907.20	1	300907.23	1	300907.26	1	300907.26	1	300907.33	1	300907.39
10	Tube Baffle Long Antibypass	1	300908.60	1	300908.70	2	300908.40	2	300908.43	2	300908.48	2	300908.53	2	300908.61	2	300908.69
	Tube "T" Baffle Assembly	1	400313	1	400313	1	400313	1	400313	1	400313	1	400313	1	400313	1	400313
<b>FLUE COLLECTOR PANELS</b>																	
11	Flue Collector Side Starter Panel (Burner End)	1	400324	1	400323	1	400324	1	400322	1	400324	1	400322	1	400322	1	400322
12	Flue Collector Side Filler Panel (Right Hand)	—	—	—	—	1	400326	1	400326	1	400326	1	400326	2	400326	2	400326
13	Flue Collector Side End Panel (Right Hand)	1	400326	1	400326	1	400325	1	400325	1	400326	1	400326	1	400325	1	400326
14	Flue Collector - Front Assembly	1	400327	1	400327	1	400327	1	400327	1	400327	1	400327	1	400327	1	400327
15	Flue Collector - Rear Assembly	1	400328	1	400328	1	400328	1	400328	1	400328	1	400328	1	400328	1	400328
16	Flue Collector Top/Stack Assembly	1	400329	1	400329	1	400329	1	400329	1	400329	1	400329	1	400329	1	400329
17	Flue Collector Top Filler Panel(s)	1	300445.67	2	300445.38	2	300445.43	2	300445.47	2	300445.51	2	300445.56	2	300445.64	2	300445.72
18	Flue Collector Wrap Insulation	1	300911.350	1	300911.400	1	300911.450	1	300911.500	1	300911.550	1	300911.600	1	300911.700	1	300911.800
19	Flue Collector End Filler Panel Assembly (Front)	1	400330	1	400330	1	400330	1	400330	1	400330	1	400330	1	400330	1	400330
20	Flue Collector End Filler Panel Assembly (Rear)	1	400331	1	400331	1	400331	1	400331	1	400331	1	400331	1	400331	1	400331

**RV/EB SERIES  
FORCED DRAFT STEAM  
PARTS LIST**

ITEM	DESCRIPTION	RV350-S		RV400-S		RV450-S		RV500-S		RV550-S		RV600-S		RV700-S		RV800-S	
		REQ	PART NO.	REQ	PART NO.	REQ	PART NO.	REQ	PART NO.	REQ	PART NO.	REQ	PART NO.	REQ	PART NO.	REQ	PART NO.
<b>TUBE ACCESS DOOR</b>																	
21	Tube Access Left (Starter) Panel Assembly	1	400332	1	400332	1	400332	1	400332	1	400332	1	400332	1	400332	1	400332
22	Tube Access Center (Filler) Panel Assembly	1	400333	2	400333	2	400333	3	400333	3	400333	4	400333	5	400333	6	400333
23	Tube Access Right (Hinged) Panel Assembly	1	400334	1	400334	1	400334	1	400334	1	400334	1	400334	1	400334	1	400334
24	Tube Panel Clamp (Standard Horizontal)	4	38458	6	38458	6	38458	8	38458	8	38458	10	38458	12	38458	14	38458
25	Tube Panel Clamp (Vertical)	1	38460	1	38460	1	38460	1	38460	1	38460	1	38460	1	38460	1	38460
26	Tube Panel Clamp (Bottom Peepsite End)	1	38459	1	38458	1	38459	1	38458	1	38459	1	38458	1	38458	1	38458
27	Tube Panel Clamp (Top Peepsite End)	1	38459.5	1	38458	1	38459.5	1	38458	1	38459.5	1	38458	1	38458	1	38458
<b>JACKET</b>																	
28	Jacket Front	1	38252	1	38252	1	38252	1	38252	1	38252	1	38252	1	38252	1	38252
29	Jacket Rear	1	38254	1	38254	1	38254	1	38254	1	38254	1	38254	1	38254	1	38254
30	Jacket Side (Type A)	1	38327	1	38328	1	38329	1	38330	1	38331	1	38332	1	38334	1	38335
31	Jacket Side (Type B)	2	38338	2	38338	3	38338	3	38338	3	38338	4	38338	4	38338	5	38338
32	Jacket Top (Burner End)	1	38380	1	38383	1	38383	1	38383	1	38392	1	38392	1	38401	1	38401
33	Jacket Top (Center)	1	38381	1	38384	1	38387	1	38390	1	38393	1	38396	1	38402	1	38408
34	Jacket Top (Peepsite End)	1	38382	1	383882	1	38382	1	38382	1	38394	1	38394	1	38394	1	38394
35	Jacket Top (Filler End)	2	300455	2	300455	2	300455	2	300455	2	300455	2	300455	2	300455	2	300455
36	Jacket Door Top Filler Panel Assembly	1	400160.450	1	400160.500	1	400160.550	1	400160.600	1	400160.650	1	400160.700	1	400160.800	1	400160.900
37	Jacket Corner Trim	4	38468	4	38468	4	38468	4	38468	4	38468	4	38468	4	38468	4	38468
38	Jacket Side Horizontal Molding	2	38476	2	38477	2	38478	2	38479	2	38480	2	38481	3	38483	3	38484
39	Jacket Front/Rear Molding Vertical	4	38463	4	38463	4	38463	4	38463	4	38463	4	38463	4	38463	4	38463
40	Jacket Front/Rear Molding Horizontal	2	38466	2	38466	2	38466	2	38466	2	38466	2	38466	2	38466	2	38466
41	Jacket Framework Assembly	1	400335.350	1	400335.400	1	400335.450	1	400335.500	1	400335.550	1	400335.600	1	400335.700	1	400335.800
42	Jacket Front Upper Drum Patch	1	300456	1	300456	1	300456	1	300456	1	300456	1	300456	1	300456	1	300456
43	Jacket Rear Upper Drum Patch	1	300457	1	300457	1	300457	1	300457	1	300457	1	300457	1	300457	1	300457
<b>JACKET DOOR</b>																	
44	Jacket Door Assembly Starter (Peepsite end)	1	400317	1	400318	1	400317	1	400318	1	400317	1	400318	1	400318	1	400318
45	Jacket Door Assembly (Filler)	2	400318	2	400318	3	400318	3	400318	4	400318	4	400318	5	400318	5	400319
46	Jacket Door Assembly (Second from Burner)	1	400318	1	400320	1	400318	1	400319	1	400318	1	400319	1	400319	1	400319
47	Jacket Door Assembly (Burner End)	1	400321	1	400321	1	400321	1	400321	1	400321	1	400321	1	400321	1	400321
<b>BURNER ASSEMBLY</b>																	
BURNER - See Burner Parts Data Sheet		<b>REFER TO EQUIPMENT LIST</b>															
	Burner Plug	1	38001	1	38001	1	38001	1	38001	1	38001	1	38001	1	38001	1	38001
	Rope Gasket (Ft.)	10	24621	10	24621	10	24621	10	24621	10	24621	10	24621	10	24621	10	24621



**RV/EB SERIES  
FORCED DRAFT - STEAM  
PARTS LIST**

ITEM	DESCRIPTION	RV350-S		RV400-S		RV450-S		RV500-S		RV550-S		RV600-S		RV700-S		RV800-S	
		REQ	PART NO.	REQ	PART NO.	REQ	PART NO.	REQ	PART NO.	REQ	PART NO.	REQ	PART NO.	REQ	PART NO.	REQ	PART NO.
	<b>PEEPSITE ASSEMBLY</b>																
	Fire Inspection Tube	1	8430	1	8430	1	8430	1	8430	1	8430	1	8430	1	8430	1	8430
	Nipple, 2" x 7"	1	22479	1	22479	1	22479	1	22479	1	22479	1	22479	1	22479	1	22479
	Pipe Cap 2"	1	22245	1	22245	1	22245	1	22245	1	22245	1	22245	1	22245	1	22245
	View Glass 1/4" x 2" Dia. Pyrex	1	28931	1	28931	1	28931	1	28931	1	28931	1	28931	1	28931	1	28931
	Rope Gasket 3/8" (ft.)	1	24621	1	24621	1	24621	1	24621	1	24621	1	24621	1	24621	1	24621
	<b>STEAM TRIM</b>																
	Control Panel																
	Terminal Strip *																
	Gauge Glass																
	Gauge Glass Valves																
	Pressuretrol - Operator																
	Pressuretrol - High Limit																
	Low Water Cut Off & Pump Control																
	Auxiliary Low Water Cut Off																
	Try Cocks																
	Pressure Gauge																
	Pressure Relief Valve																
	Pressure Shutoff Cock																
	Blowdown Valves (Optional)																
	<b>SERVICE TOOLS</b>																
	Tube Puller **	1	28905	1	28905	1	28905	1	28905	1	28905	1	28905	1	28905	1	28905
	Tube Driver **	1	28901	1	28901	1	28901	1	28901	1	28901	1	28901	1	28901	1	28901
	Tube Brush ***	1	28917	1	28917	1	28917	1	28917	1	28917	1	28917	1	28917	1	28917

REFER TO EQUIPMENT LIST

\* Depends on Number of Terminals Required  
 \*\* Furnished as Standard on High Pressure Steam Only  
 \*\*\* Not Standard. Available Upon Request.

Note: Refer to Illustration Parts List (Form 2360) for descriptions.

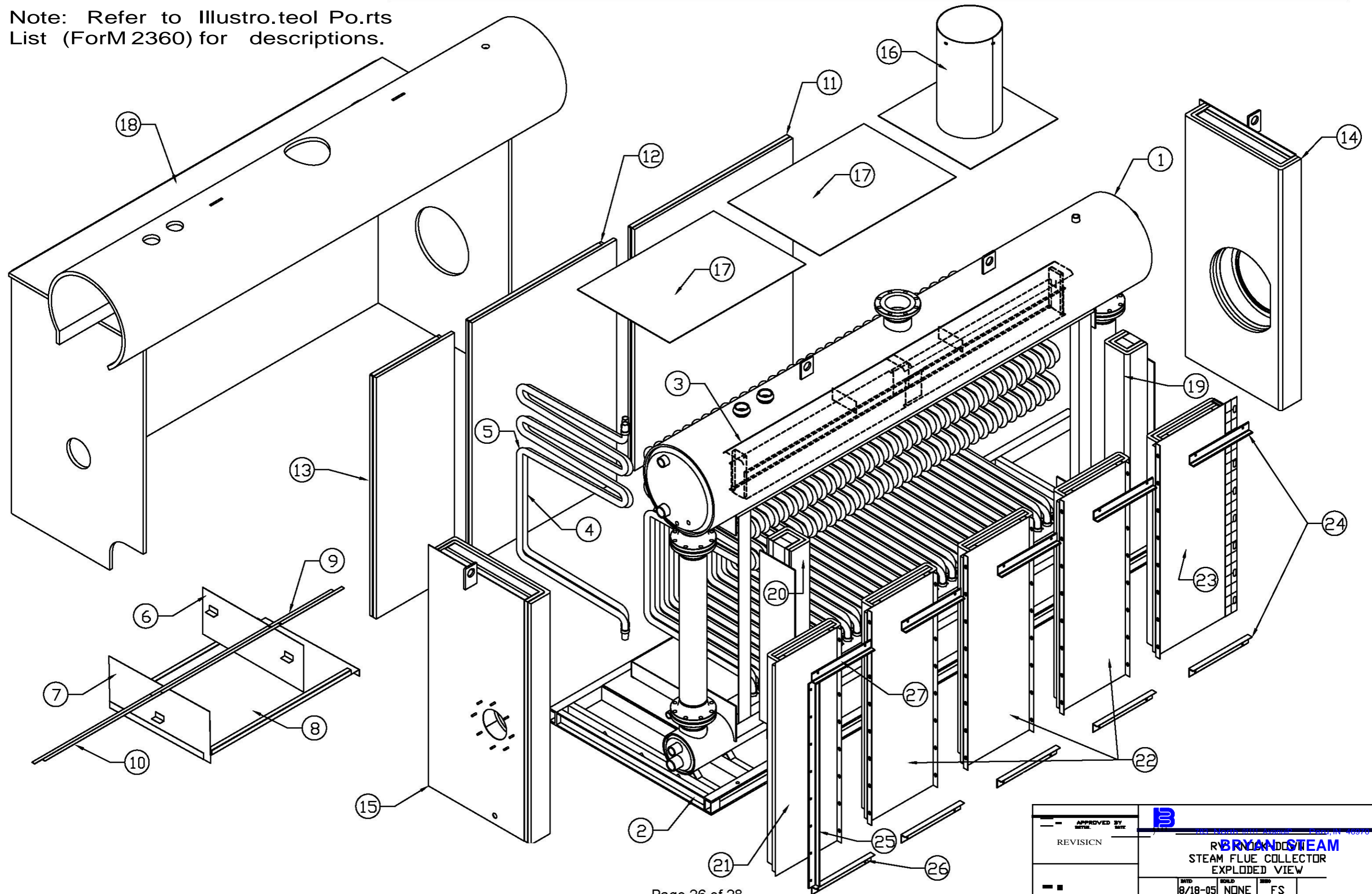

APPROVED BY DATE	 RICHMOND, INDIANA <b>BRYAN STEAM</b> STEAM FLUE COLLECTOR EXPLODED VIEW		
REVISION	DATE	SCALE	BY
	8/18-05	NONE	FS



TOP VIEW/

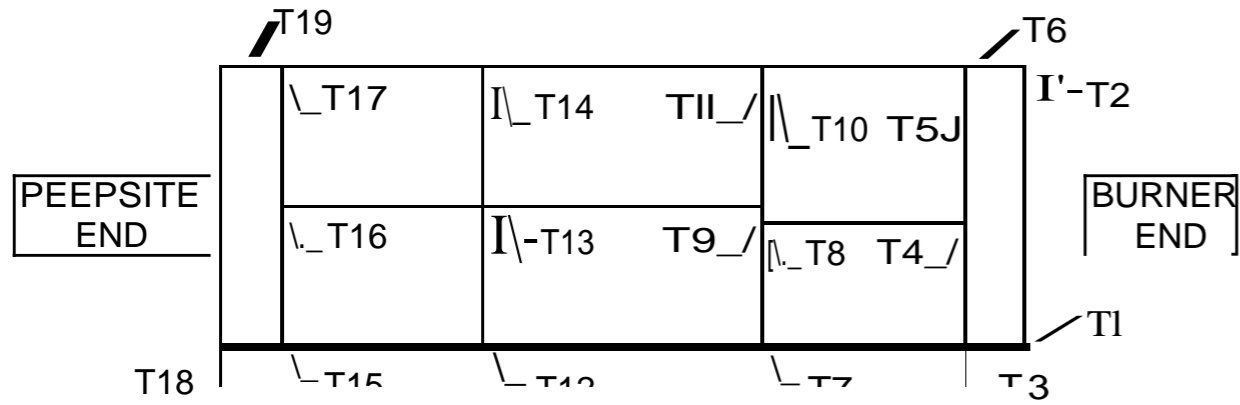

THIS DRAWING PORTRAYS RV500-S-KD

BURNER END <F>  
AND  
PEEPSITE END (R)

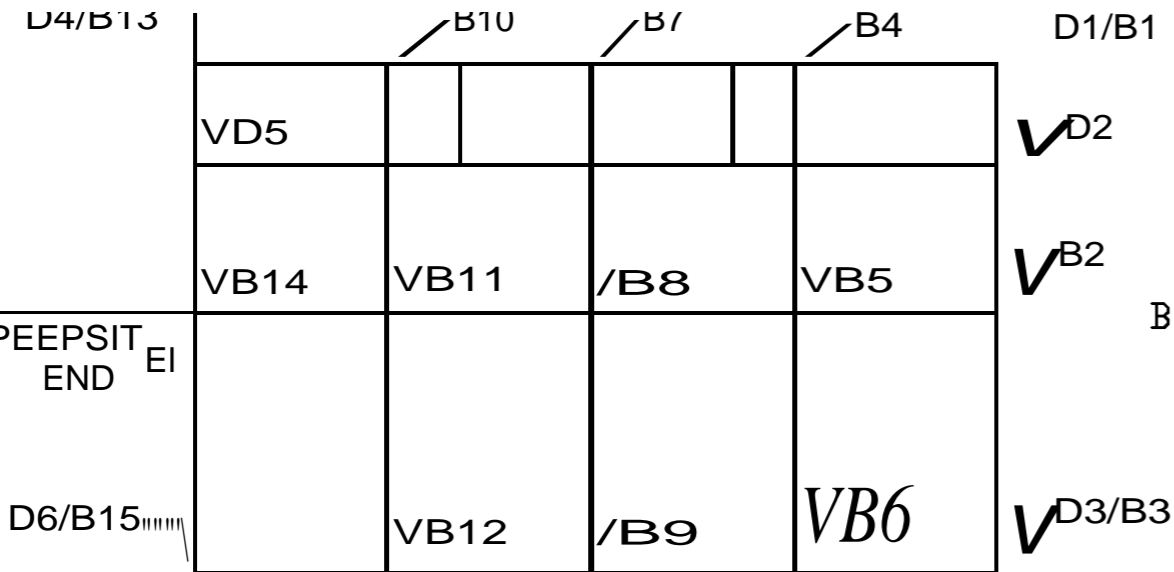
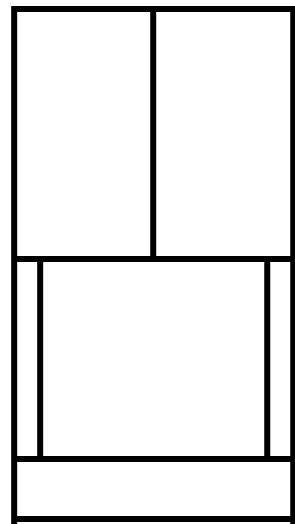

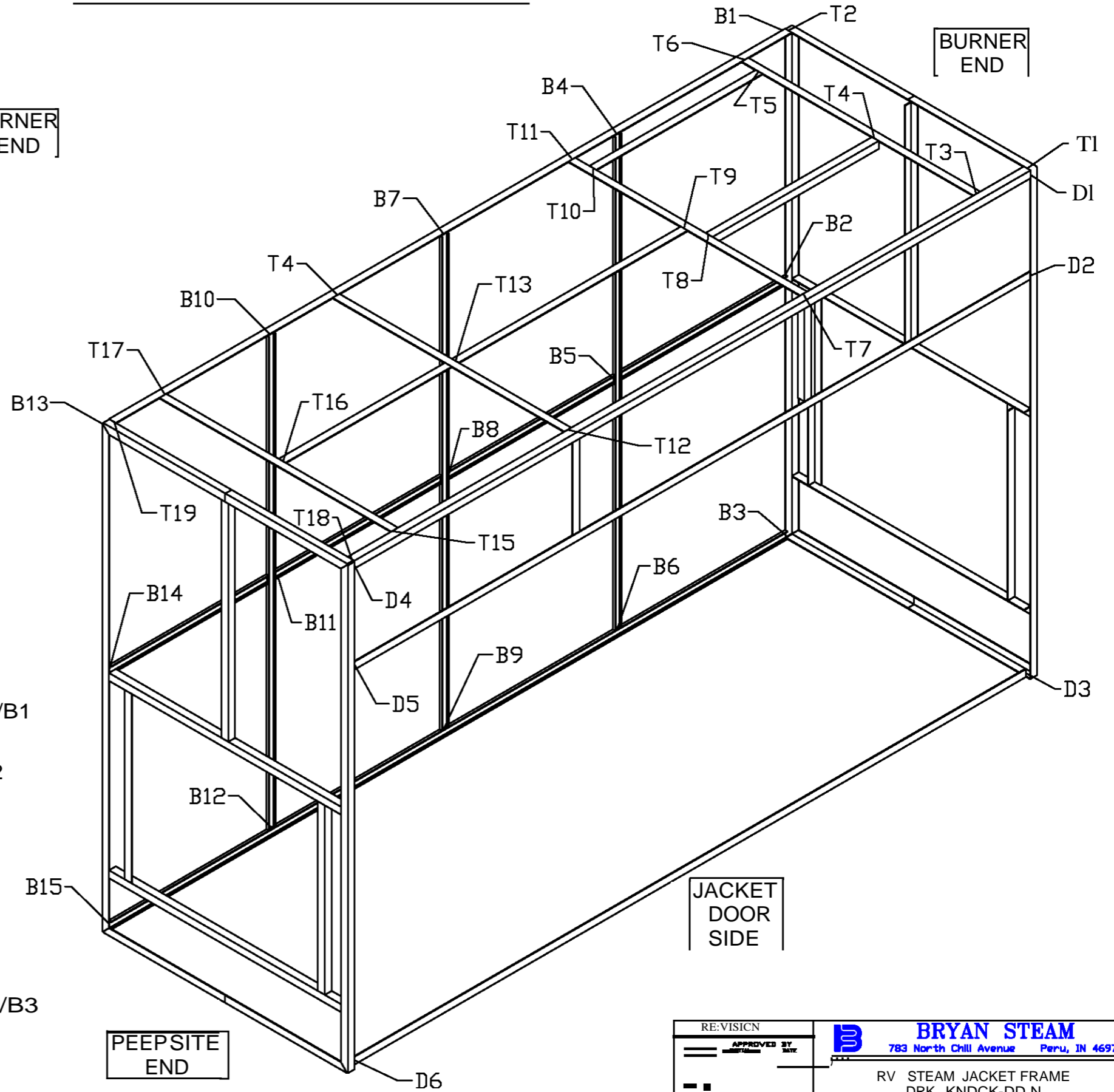

SIDE VIEW/

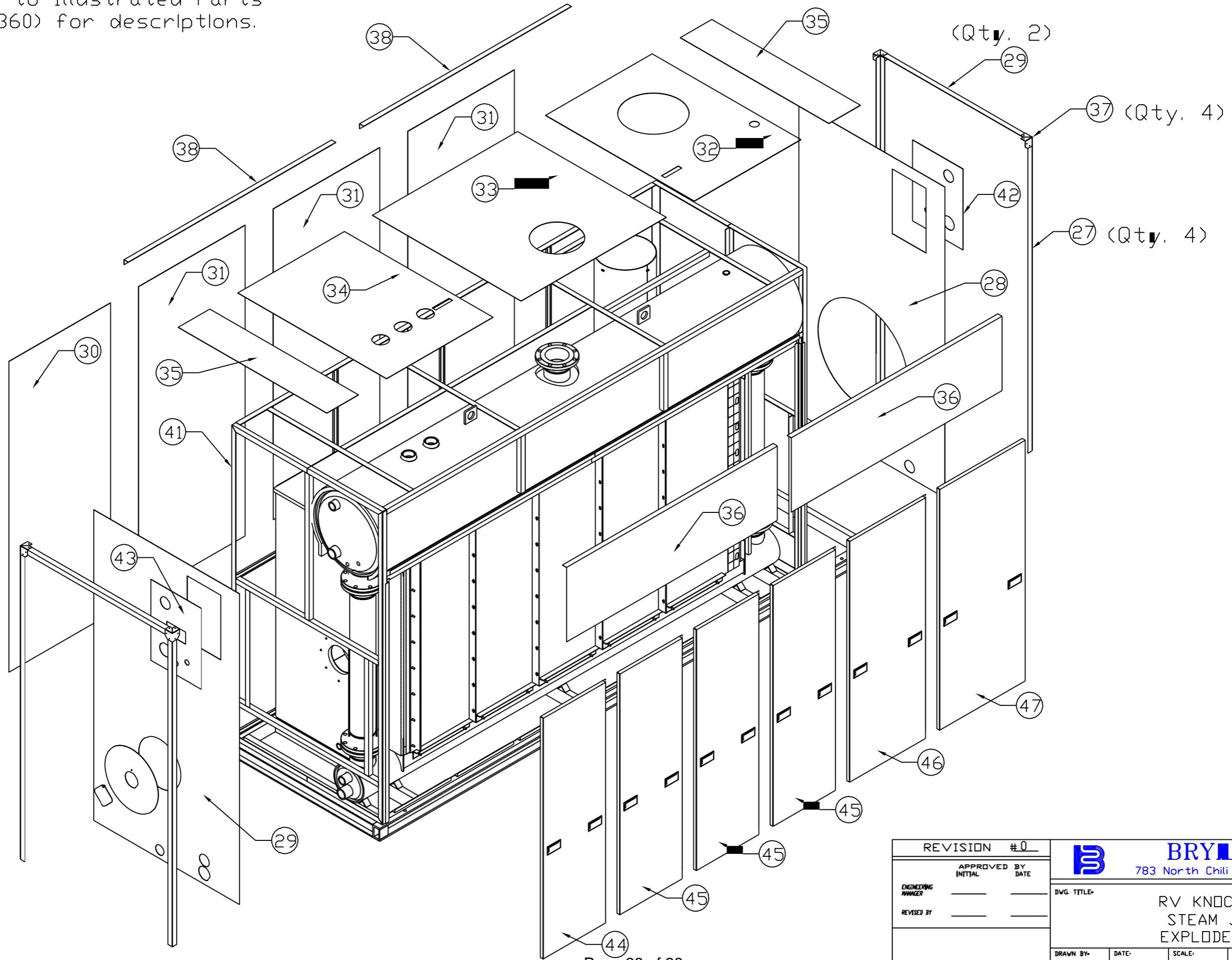

REVISION		<b>BRYAN STEAM</b>	
APPROVED BY		783 North Chili Avenue Peru, IN 46970	
RV STEAM JACKET FRAME			
DRK KNDCK-DD N			
EXPLODED VIEW			
DATE	BY	SCALE	APP
8/24/05	JSL	NONE	FS
			B21240

Note: Refer to Illustrated Parts List (Form 2360) for descriptions.



REVISION #0		 <b>BRYAN STEAM</b> 783 North Chili Avenue Peru, IN 46970		
APPROVED BY	DATE			
ENGINEERING MANAGER		DWG. TITLE:		
REVISED BY		RV KNOCK-DOWN STEAM JACKET EXPLODED VIEW		
DRAWN BY:	DATE:	SCALE:	DISK:	DWG. NO.:
RBJ	8/18/05	NONE	FS	B21235