



BFITW CONDENSING WATER HEATERS - SUBMITTAL DATA

RATINGS AND CAPACITIES		
Input - Low Fire	250,000	BTU/HR
Input - High Fire	1,250,000	BTU/HR
Output - High Fire	1,225,000	BTU/HR
DHW Recovery (40°F to 140° Rise)....	1,470	GPH
Thermal Efficiency	98.0%	
Heating Surface	100.2	Sq.Ft.
Water Content	11.0	Gallons
Fuel	Natural Gas / LP Gas	
Firing Rate	Full Modulation	
Burner Turndown	5:1	
Low NOx Emissions	< 10 ppm	
Inlet Gas Pressure (NG)	4" wc	Min.
Inlet Gas Pressure (LP)	8" wc	Min.
	14" wc	Max.
Shipping Weight, Approximate	922	lbs

ASME Section IV (Max 160 PSIG / 210°F)	
ETL Certified to ANSI Z21.10.3 / CSA 4.3	
NSF/ANSI Standard 372	

DIMENSIONS / CONNECTIONS	
- Height	42-3/4" (Note 1)
- Width	34-1/4" (Note 2)
- Length	45-1/2" (Note 3)
- Supply Connection	3" Grooved
- Return Connection	2-1/2" Grooved
- Vent / Air Intake Connections	8"
- Gas Connection	1" NPT

STANDARD EQUIPMENT	
- ASME Stainless Steel Heat Exchanger	
- Stainless Steel Pre-Mix Burner	
- Variable Speed Combustion Blower	
- Concert Control™ (24v)	
- High Limit Temperature Control, Manual Reset	
- Water Flow Switch	
- Low Water Cutoff, Manual Reset	
- Condensate Trap	
- Blocked Condensate Switch	
- ASME Temperature & Pressure Relief Valve	
- Temperature & Pressure Gauge	
- Supply, Return & DHW Temperature Sensors	
- Flue Gas Temperature Sensor	
- Air Vent Valve	
- Manual Fuel Changeover Switch	
- Modulating Gas Valve	
- Direct Spark Ignition and UV Scanner	
- High/Low Gas Pressure Switches, Manual Reset	
- Combustion Air Switch	
- Blocked Vent Switch	
- 120-208-240v/1/60 Line Voltage	
- Amp Draw: 120v (11.0); 208v (7.4) and 240v (6.5)	
- Category II and IV Venting	
- Individual or Common (Engineered) Vent System	
- CPVC, Polypropylene & Stainless Steel Acceptable *Material	
- Sealed or Room Combustion Air Intake	
- Up to 300 ft equivalent venting / air intake	

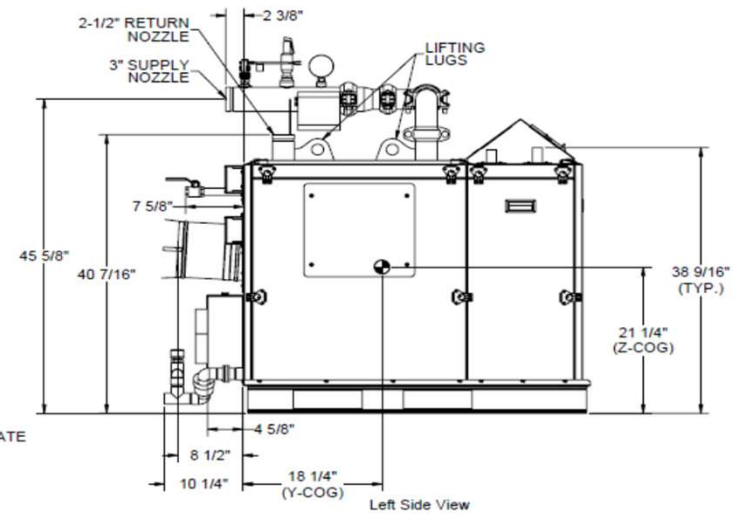
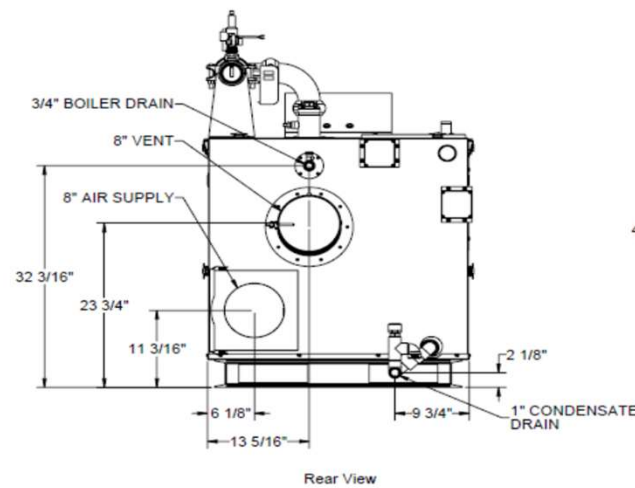
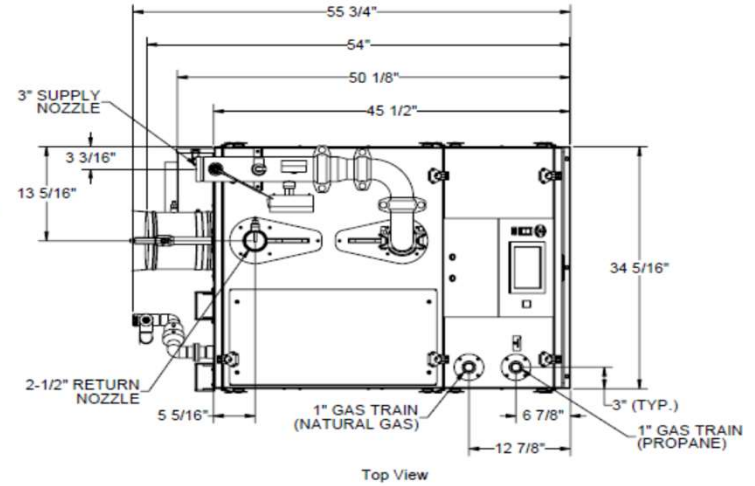
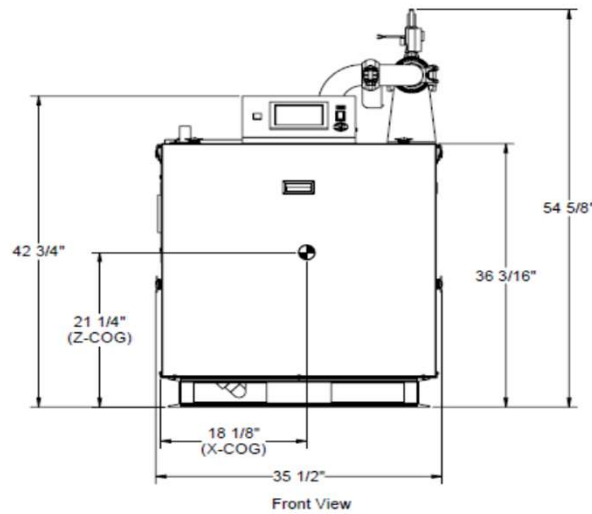

- NOTES:
1. Height dimension is from floor to top of control box.
 2. Width does not include jacket butterfly clips that require 3/4" +/- clearance on each side.
 3. Length is from jacket front to jacket rear.
 4. Dimensions shown are for reference only

FLOW REQUIREMENTS		
Water Hardness	Flow (GPM)	Δ P (Ft. Hd)
5 - 12 gpg	99	11.0
12 - 15 gpg	132	18.0

* Flue system material shall be capable of continuous operation at 210°F or higher and shall be certified to UL 1738 – venting system for gas-burning appliances cat II, III and IV.

BFITW-1250-DF

PROPERTY OF

BRYAN®

783 N Chili Ave | Peru, IN 46970

Boiler Technology Leadership Since 1916
www.bryanboilers.com

Updated 2/2024