

BFITW CONDENSING WATER HEATERS - SUBMITTAL DATA SHEET

RATINGS AND CAPACITIES		
Input - Low Fire	500,000	BTU/HR
Input - High Fire	2,500,000	BTU/HR
Output - High Fire	2,450,000	BTU/HR
DHW Recovery (40°F to 140° Rise).....	2,940	GPH
Thermal Efficiency	98.0%	
Heating Surface	300.7	Sq.Ft.
Water Content	34.6	Gallons
Fuel	Natural Gas or LP Gas	
Firing Rate	Full Modulation	
Burner Turndown	5:1	
Low NOx Emissions	< 10 ppm	
Inlet Gas Pressure (NG)	4" wc	Min.
Inlet Gas Pressure (LP)	8" wc	Min.
	14" wc	Max.
Shipping Weight, Approximate	2,038	lbs

ASME Section IV (Max 160 PSIG / 210°F)	
ETL Certified to ANSI Z21.13 / CSA 4.9	
UL 795 / CSA 3.1	
NSF/ANSI Standard 372	

DIMENSIONS / CONNECTIONS		
- Height	55"	(Note 1)
- Width	46"	(Note 2)
- Length	75-5/8"	(Note 3)
- Supply Connection	4" Grooved	
- Return Connection	4" Grooved	
- Vent / Air Intake Connections	10"	
- Gas Connection	2" NPT	

STANDARD EQUIPMENT		
- ASME Stainless Steel Heat Exchanger		
- Stainless Steel Pre-Mix Burner		
- Variable Speed Combustion Blower		
- Concert Control™ (24v)		
- High Limit Temperature Control, Manual Reset		
- Water Flow Switch		
- Low Water Cutoff, Manual Reset		
- Condensate Trap		
- Blocked Condensate Switch		
- ASME Temperature & Pressure Relief Valve		
- Temperature & Pressure Gauge		
- Supply, Return & DHW Temperature Sensors		
- Flue Gas Temperature Sensor		
- Air Vent Valve		
- Modulating Gas Valve		
- Direct Spark Ignition and UV Scanner		
- High/Low Gas Pressure Switches, Manual Reset		
- Combustion Air Switch		
- Blocked Vent Switch		
- 120-208-240v/1/60 Line Voltage		
- Amp Draw: 120v (13.5); 208v (8.2) and 240v (7.7)		
- 208-240-460v/3ph/60hz Line Voltage		
- Amp Draw: 208v (11.0); 240v (9.9) and 460v (6.4)		
- Category II and IV Venting		
- Individual or Common (Engineered) Vent System		
- CPVC, Polypropylene & Stainless Steel Acceptable *Material		
- Sealed or Room Combustion Air Intake		
- Up to 300 ft equivalent venting / air intake		

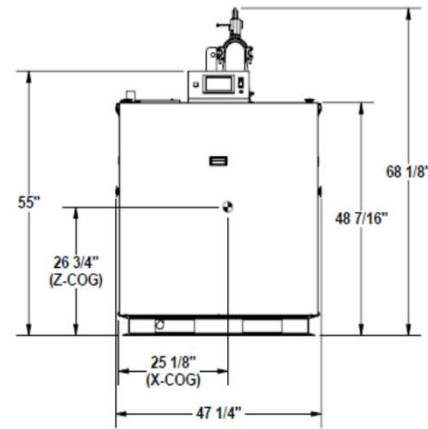

Front View

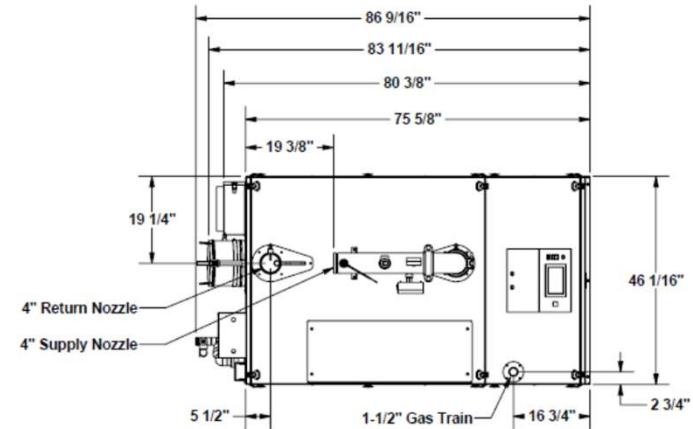

Top View

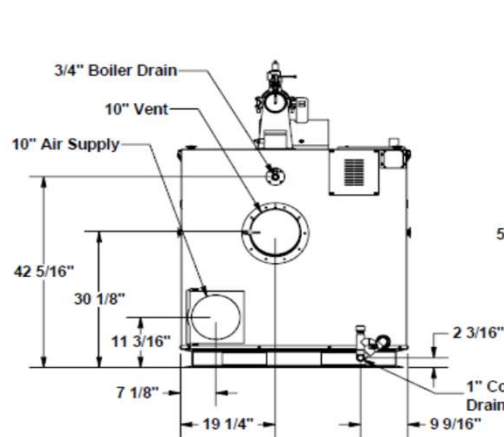

Rear View

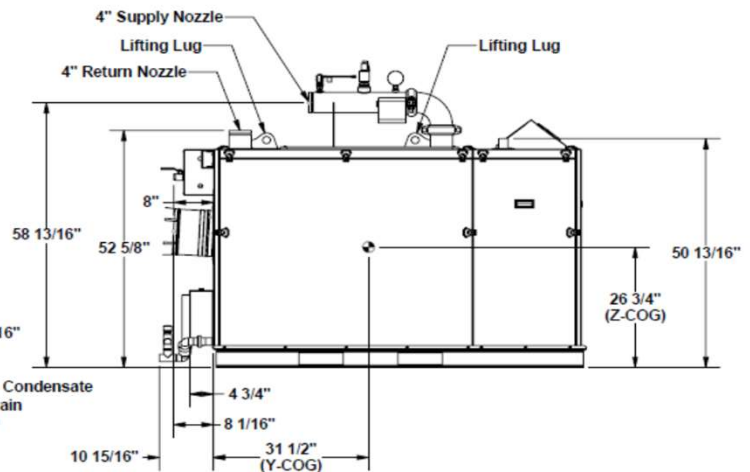

Left Side View

- NOTES:
1. Height dimension is from floor to top of control box.
 2. Width does not include jacket butterfly clips that require 3/4" +/- clearance on each side.
 3. Length is from jacket front to jacket rear.
 4. Dimensions shown are for reference only

FLOW REQUIREMENTS		
Water Hardness	Flow (GPM)	r P (Fl. Hd)
5 - 12 gpg	214	13.0
12 - 15 gpg	285	21.0

* Flue system material shall be capable of continuous operation at 210°F or higher and shall be certified to UL 1738 – venting system for gas-burning appliances cat II, III and IV.

BFITW-2500
PROPERTY OF BRYAN [®]
783 N Chili Ave Peru, IN 46970
Boiler Technology Leadership Since 1916 www.bryanboilers.com
Updated 2/2024