

# AMPW CONDENSING WATER HEATERS - SUBMITTAL DATA SHEET

RATINGS AND CAPACITIES		
Input - Low Fire .....	800,000	BTU/HR
Input - High Fire .....	4,000,000	BTU/HR
Output - High Fire .....	3,920,000	BTU/HR
DHW Recovery (40°F to 140° Rise)....	4,704	GPH
Thermal Efficiency .....	98.0%	
Heating Surface .....	402.9	Sq.Ft.
Water Content .....	45.3	Gallons
Fuel .....	Natural Gas / LP Gas	
Firing Rate .....	Full Modulation	
Burner Turndown .....	5:1	
Low NOx Emissions .....	< 10 ppm	
Inlet Gas Pressure (NG) .....	4" wc	Min.
Inlet Gas Pressure (LP) .....	8" wc	Min.
	14" wc	Max.
Shipping Weight, Approximate .....	2,485	lbs

ASME Section IV (Max 160 PSIG / 210°F)	
ETL Certified to ANSI Z21.13 / CSA 4.9	
UL 795 / CSA 3.1	
NSF/ANSI Standard 372	

DIMENSIONS / CONNECTIONS		
- Height .....	55"	(Note 1)
- Width .....	44"	(Note 2)
- Length .....	92"	(Note 3)
- Supply Connection .....	4" Grooved	
- Return Connection .....	4" Grooved	
- Vent / Air Intake Connections .....	12"	
- Gas Connection .....	2" NPT	

STANDARD EQUIPMENT	
- ASME Stainless Steel Heat Exchanger	
- Stainless Steel Pre-Mix Burner	
- Variable Speed Combustion Blower	
- Concert Control™ (24v)	
- High Limit Temperature Control, Manual Reset	
- Water Flow Switch	
- Low Water Cutoff, Manual Reset	
- Condensate Trap	
- Blocked Condensate Switch	
- ASME Temperature & Pressure Relief Valve	
- Temperature & Pressure Gauge	
- Supply, Return & DHW Temperature Sensors	
- Flue Gas Temperature Sensor	
- Air Vent Valve	
- Manual Fuel Changeover Switch	
- Modulating Gas Valve	
- Direct Spark Ignition and UV Scanner	
- High/Low Gas Pressure Switches, Manual Reset	
- Combustion Air Switch	
- Blocked Vent Switch	
- 208-240-460v/3ph/60hz Line Voltage	
- Amp Draw: 208v (11.0); 240v (9.9) and 460v (6.4)	
- Category II and IV Venting	
- Individual or Common (Engineered) Vent System	
- CPVC, Polypropylene & Stainless Steel Acceptable *Material	
- Sealed or Room Combustion Air Intake	
- Up to 300 ft equivalent venting / air intake	

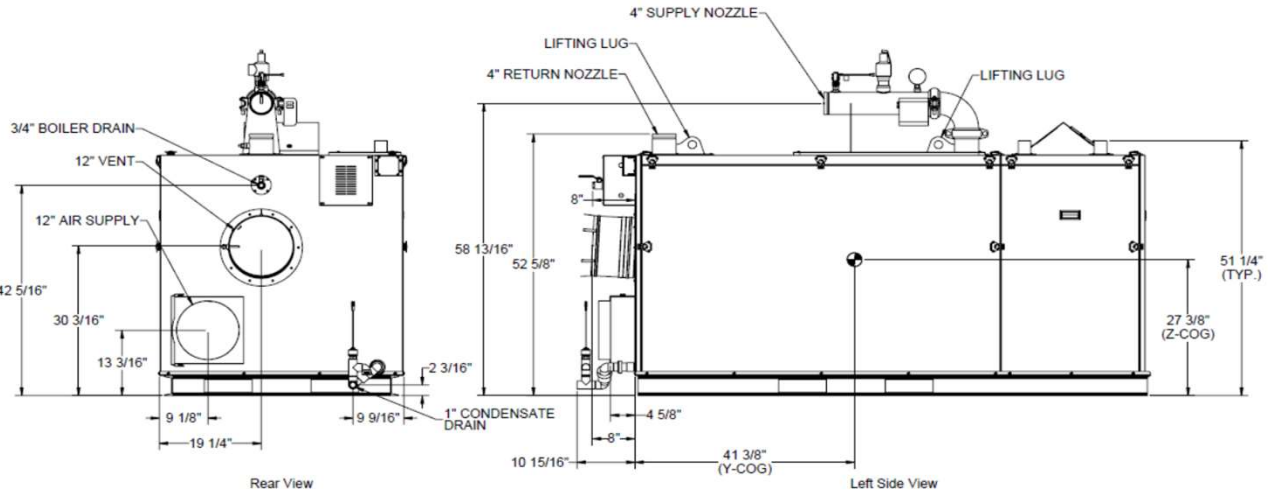
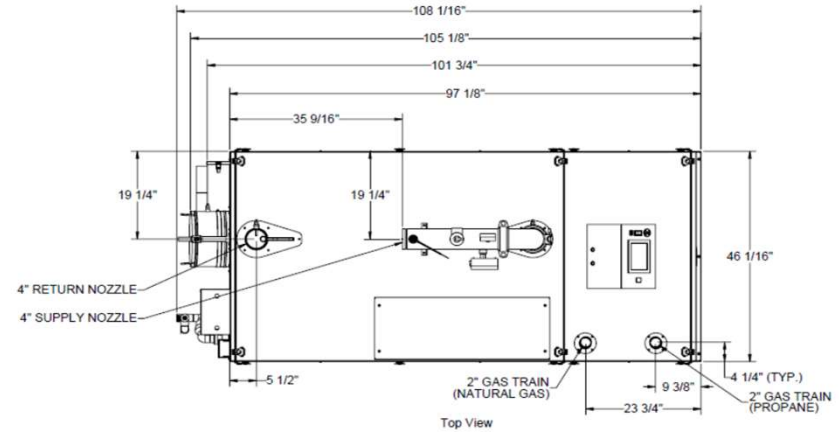
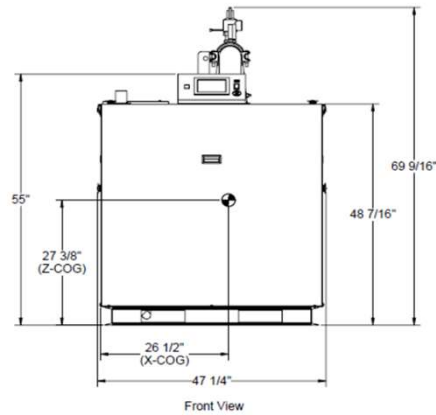

- NOTES:
1. Height dimension is from floor to top of control box.
  2. Width does not include jacket butterfly clips that require 3/4" +/- clearance on each side.
  3. Length is from jacket front to jacket rear.
  4. Dimensions shown are for reference only

FLOW REQUIREMENTS		
Water Hardness	Flow (GPM)	r.P (Ft. Hd)
5 - 12 gpg	280	11.0
12 - 15 gpg	372	18.0

\* Flue system material shall be capable of continuous operation at 210°F or higher and shall be certified to UL 1738 – venting system for gas-burning appliances cat III, III and IV.

<b>BFITW-4000-DF</b>
PROPERTY OF <b>BRYAN®</b> 783 N Chili Ave   Peru, IN 46970
Boiler Technology Leadership Since 1916 www.bryanboilers.com
Updated 2/2024