

BFIT

Commercial High Efficiency Condensing Boilers and Water Heaters

BFIT-L
399-999 MBH



BFIT
1000-3999 MBH

A Better Fit For Any Boiler Room

SAVES SPACE

- Reduced footprint, zero clearance (BFIT-L models)
- Stackable/rackable design doubles MBH/sq.ft. (BFIT-L stackable as boiler model only)

STREAMLINES REPLACEMENT

- 3-in-1 vent connector (BFIT-L models), multiple venting options
- Up to 300 equivalent ft. of venting on BFIT models (200 equivalent ft. for BFIT-L models)
- Simplified wiring - separate low/high voltage boards

SIMPLIFIED SPECIFICATION & INSTALLATION

- CSD-1 built-in (gas train & controls)
- Advanced Concert™ control system
 - Touch screen with intuitive navigation and menus
 - Cascade up to 8 boilers
 - Data/event logging
- Modbus connectivity

RELIABILITY & SERVICEABILITY

- Commercial-grade water tube heat exchanger
- Easy access to all boiler service locations
- Complete control panel access: slide out (BFIT-L models), external (BFIT models)

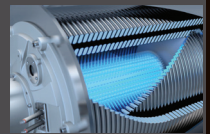

B™ **BRYAN**®
BOILERS

BFIT-L

Boilers & Water Heaters



- CSD-1 compliant
- Double MBH per sq. ft.
 - Stackable, hardware included (boiler models only)
 - Zero clearance
- Fits through standard doorways
- Modbus connectivity, cascade up to 8 individual units
- Outdoor models available – no upcharge
- 3-in-1 vent connector (CPVC, PP, SS)
- Venting of up to 200 (combined) equivalent ft.
- 10:1 turndown, natural gas or LP
- Easy service and maintenance – complete service access to burner, combustion chamber, and slide-out boiler control vestibule
- Warranty: 10-year limited heat exchanger, 1-year parts & burner



PRESSURE VESSEL

- Stainless steel watertube heat exchanger
- ASME Section IV-certified, "H" Stamp
- MAWP 160 PSIG, design temp 210°F
- CSD-1 compliant

COMBUSTION

- Stainless steel pre-mix burner
- Low NOx emissions (<10 ppm);
- Full modulation, 10:1 turndown
- 4" wc to 14" wc inlet gas pressure
- 8" wc LP min
- Direct spark ignition system
- High/low gas pressure switches w/ manual reset
- Combustion air switch
- Modulating gas valve
- Variable speed combustion blower
- Air proving switch & blocked vent switch

VENTING

- CPVC, polypropylene or stainless steel materials acceptable
- Air intake – sealed combustion or room air
- Category II or IV venting
- Individual or common (engineered) venting systems

EQUIPMENT

- Concert™ control
- High limit w/ manual reset safety temperature control
- Low water cutoff w/ manual reset
- Water flow switch
- Supply & return, and water temperature sensors
- Flue gas temperature sensor
- Condensate trap
- Blocked condensate switch
- Pressure & temperature gauge
- ASME safety temperature & pressure relief valve (boilers: 50 PSI standard; 30, 60, 75, 100, 125, or 150 available - water heaters: 150 PSI standard)

ELECTRICAL

- High voltage printed circuit board (PCB)
- 120 VAC / 60 Hz / 1PH power supply
 - 120 VAC manual reset external limit contacts
 - Three sets of pump contacts
 - PCB fused connections

Printed circuit board (PCB)

- 24 VAC enable/disable sensor contacts
- 24 VAC proving switch or manual reset ext. limit contacts
- 24 to 120 VAC lockout alarm contacts
- 24 VAC EnviraCom thermostat contacts
- DHW demand contacts
- Remote header sensor contacts
- DHW tank sensor contacts
- Peer-to-peer communication contacts
- EMS interface contacts
- Remote 4-20mA contacts

BFIT-L Dimensions (Inches)

Model	A	Vent Connection	Gas Connection NPT	Supply (NPT)	Return (NPT)
BFIT(W)-400	37-3/4	4	3/4	2	2
BFIT(W)-500	37-3/4	4	3/4	2	2
BFIT(W)-650	53-7/8	6	1	2	2
BFIT(W)-800	53-7/8	6	1	2	2
BFIT(W)-1000L	53-7/8	6	1	2	2

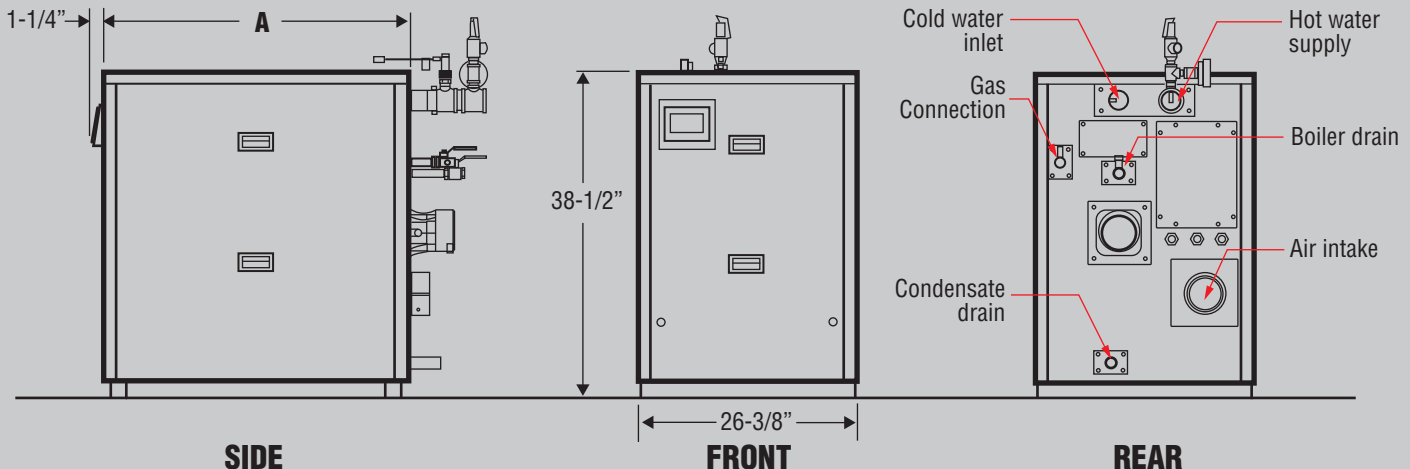

Boilers & Water Heaters

- CSD-1 compliant
- 50% smaller footprint compared to competitors
- Stackable with optional racking system
- Top water connections saves space
- Modbus connectivity, cascade up to 8 individual units
- 5:1 turndown, natural gas or LP
- AL29-4C, PP, or CPVC venting, up to 300 (combined) equivalent feet
- Complete access to burner and combustion chamber for ease of service
- Warranty: 10-year limited heat exchanger, 1-year parts & burner

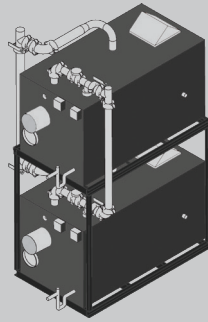

PRESSURE VESSEL

- Watertube stainless steel heat exchanger
- ASME Section IV-certified, "H" Stamp
- MAWP 160 PSIG & design temp 210°F
- CSD-1 compliant

COMBUSTION DESIGN

- Stainless steel pre-mix burner
- Low NOx emissions (<10 ppm)
- 4" wc to 14" wc inlet gas pressure
- 8" wc LP min
- Direct spark ignition system
- High & low gas pressure switches w/ manual reset
- Zero governor gas valve
- Variable speed combustion blower

- Air proving switch
- Blocked vent switch

VENTING

- CPVC, polypropylene or stainless steel materials acceptable
- Air intake - sealed combustion or room air
- Category II or IV venting
- Individual or common (engineered) venting systems

EQUIPMENT

- Concert™ control
- High limit w/ manual reset safety temp. control
- Low water cutoff w/ manual reset
- Water flow switch

- Supply & return water temperature sensors
- Flue gas temperature sensor
- Condensate trap
- Blocked condensate switch
- Pressure & temperature gauge
- ASME safety temperature & pressure relief valve (boilers: 50 PSI standard; 30, 60, 75, 100, 125, or 150 available - water heaters: 150 PSI standard)

ELECTRICAL

- High voltage printed circuit board (PCB)
- 120, 208 or 240 VAC / 60 Hz / 1PH power supply
- VAC manual reset external limit contacts
- Three sets of pump contacts
- PCB fused connections
- Printed Circuit Board (PCB)
- 24 VAC enable/disable sensor contacts

- 24 VAC proving switch or manual reset ext. limit contacts
- 24 to 120 VAC lockout alarm contacts
- 24 VAC EnviraCom thermostat contacts
- DHW demand contacts
- Remote header sensor contacts
- DHW tank sensor contacts
- Outdoor air sensor contacts
- Peer-to-peer communication contacts
- EMS interface contacts
- Remote 4-20mA contacts

BFIT Dimensions (Inches)

Model	A	B	C	Vent Connection	Gas Connection NPT	Supply (NPT)	Return (NPT)
BFIT(W)-1000	45-1/2	34-1/4	42-3/4	8	1	3	2-1/2
BFIT(W)-1250	45-1/2	34-1/4	42-3/4	8	1	3	2-1/2
BFIT(W)-1500	66-1/8	34-1/4	42-3/4	8	1-1/4*	3	2-1/2
BFIT(W)-2000	66-1/8	34-1/4	42-3/4	8	1-1/4	3	2-1/2
BFIT(W)-2500	76	46	55	10	1-1/2	4	4
BFIT(W)-3000	76	46	55	10	1-1/2	4	4
BFIT(W)-3500	98	46	55	10	2	4	4
BFIT(W)-4000	98	46	55	10	2	4	4

*BFIT(W)-1500 connection 1" NPT

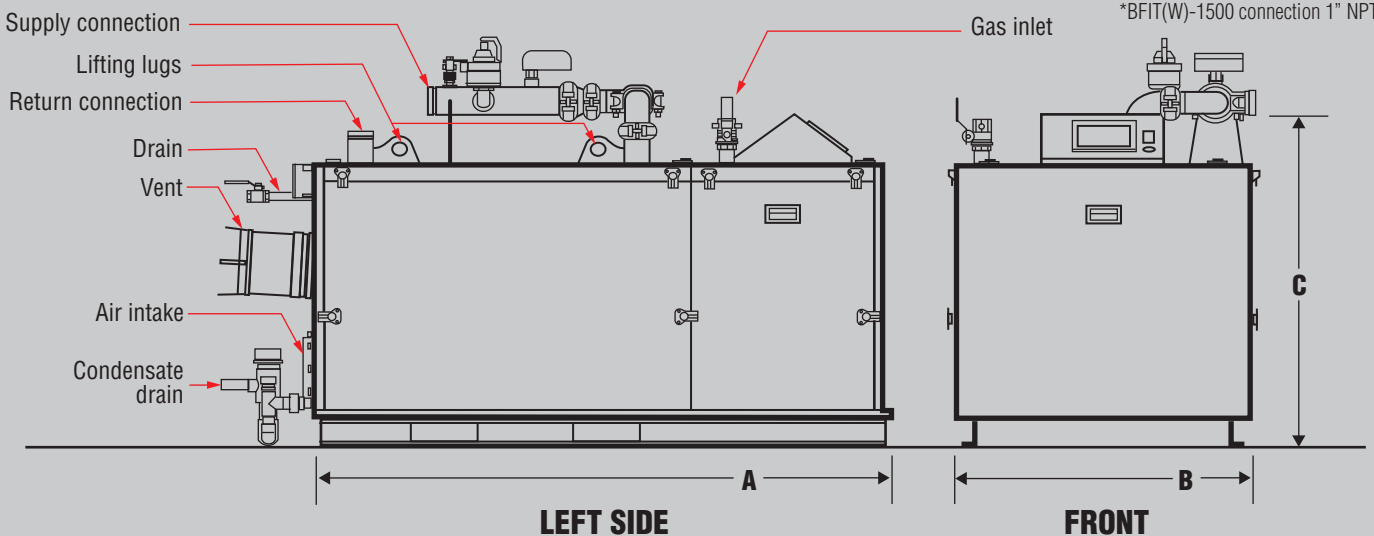

BFIT/BFIT-L

Technical Information



Advanced
Control
System

BFIT-L ³ Ratings & Specifications						
Model	Input (MBH)		Gross Output (MBH)	DHW Recovery ² (GPH)	Thermal Efficiency (%)	Approx. Shipping Weight (lbs.)
	Min	Max				
BFIT-400	40	399	387	—	97	460
BFITW-400 ¹	40	399	391	470	98	460
BFIT-500	50	500	485	—	97	470
BFITW-500 ¹	50	500	490	588	98	470
BFIT-650	65	650	631	—	97	530
BFITW-650 ¹	65	650	637	764	98	530
BFIT-800	80	800	776	—	97	560
BFITW-800 ¹	80	800	784	941	98	560
BFIT-1000L	99	999	969	—	97	600
BFITW-1000L ¹	99	999	979	1176	98	600

NOTES:
 1. Water heater model
 2. Based on 40°F to 140°F temperature rise
 3. All BFIT-L boiler and water heater models are Energy Star certified

BFIT Ratings & Specifications						
Model	Input (MBH)		Gross Output (MBH)	DHW Recovery ² (GPH)	Thermal Efficiency (%)	Approx. Shipping Weight (lbs.)
	Min	Max				
BFIT-1000 ³	200	1000	970	—	97	922
BFITW-1000 ^{1,3}	200	1000	980	1188	98	922
BFIT-1250 ³	250	1250	1213	—	97	922
BFITW-1250 ^{1,3}	250	1250	1225	1485	98	922
BFIT-1500 ³	300	1500	1455	—	97	1217
BFITW-1500 ^{1,3}	300	1500	1470	1782	98	1217
BFIT-2000 ³	399	1999	1939	—	97	1217
BFITW-2000 ^{1,3}	399	1999	1659	2376	98	1217
BFIT-2500	500	2500	2425	—	97	2281
BFITW-2500 ^{1,3}	500	2500	2500	2970	98	2281
BFIT-3000	600	3000	2910	—	97	2281
BFITW-3000 ^{1,3}	600	3000	2940	3564	98	2281
BFIT-3500	700	3500	3395	—	97	2281
BFITW-3500 ^{1,3}	700	3500	3430	4158	98	2281
BFIT-4000	799	3999	3879	—	97	2281
BFITW-4000 ^{1,3}	799	3999	3919	4752	98	2281

NOTES:
 1. Water heater model
 2. Based on 40°F to 140°F temperature rise
 3. Energy Star certified

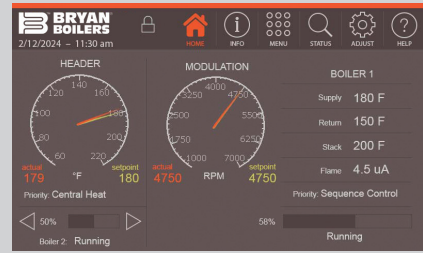

- Color touchscreen, real time readouts
- Intuitive navigation
- 3-level password protection



- Self-guided diagnostics
- Fault identification and correction
- Factory default settings
- Timed setback capability



- Time/date stamp on reports
- Stores up to 4 months of data
- Calculates cycle and run times
- Resettable



©2024 Bryan Steam, LLC.
 783 N. Chili Avenue, Peru, IN 46970
 765-473-6651